

HM Collamat AG
Bodenmattstrasse 34
CH-4153 Reinach
Switzerland

Phone +41 61 756 28 28
Fax +41 61 756 29 29
contact@collamat.ch
www.collamat.ch

Collamat 3600

Technical handbook

Index

Page

1	Safety advices	4
1.1	Important Warnings	4
1.2	Danger Indications	4
1.3	Symbol descriptions	5
2	Introduction	6
2.1	General informations	6
2.2	The labeler C3600	6
2.2.1	Prevention of accidents	7
2.2.2	Noise suppression	7
2.2.3	Mechanical stability	7
2.3	Assembly parts	8
3	Mechanical adjustments	9
3.1	Traction unit	9
3.1.1	Threading the labelweb	9
3.1.2	Adjustment of rewinder coupling force	9
3.1.3	Readjustment of paper brake	10
3.1.4	Longitudinal adjustment on the module rail	10
3.2	Flap adapter	11
3.2.1	Inclination adjustment of flap adapter	11
3.2.2	Adjustment of the pressure roller of the flap adapter	11
3.3	Adjustment of the optical label scanner	12
3.4	Adjustment of the mechanical label scanner	13
4	Technical description	14
4.1	Dispenser board	14
4.1.1	Power supply	14
4.1.2	Motordriver	14
4.1.3	Controller	14
4.2	Signals and connection diagrams	15
4.2.1	Inputs	16
4.2.2	Outputs	16
4.2.3	Isolated output IFEED	17
4.2.4	Open-Collector-output IFEED	17
4.2.5	Currentsource-output	17
4.3	Connection diagrams BUS X101, X102	18
4.4	Transformer wiring	18
4.5	Connection of the mains input	19
4.6	Grounding of the labeler	19
4.7	Connection of the mains output	20

Index

Page

4.8	Connection of the frontpanel	20
4.9	Motor and motorcable	21
5	Firmware	22
5.1	Normalmode	22
5.2	DIL-switches	23
5.2.1	DIL-switch TEST	23
5.2.2	DIL-switch DIR	23
6	Trouble shooting	24
6.1	Fuses	24
6.2	Status LEDs	24
7	Peripheral units and sensors	25
7.1	Optical label scanner	25
7.2	Goods scanners	25
7.2.1	G&S measuring IR-scanner	25
7.2.2	NPN-Reflective scanner	25
7.3	Magnet adapter	26
7.4	Flatprinting unit	27
7.4.1	Flatprinter board	27
8	Control signals for external units	28
8.1	How to connect a goods scanner	28
9	Electrical installation	29
9.1	Introduction	29
10	Testmode	31
10.1	Test software	32
10.1.1	Motortest	32
10.1.2	Motor intervall test	33
10.1.3	BUS-signal selftest	33
10.1.4	Signal display	34
10.1.5	DIL-switch settings	34
10.1.6	Potentiometer settings	34
10.1.7	Firmware Version	35
11	Control of a hotstamp with the IFEED signal	36
12	Cabling and setting up	37
12.1	Cabling	37
12.2	Setting up	37
13	Version numbers	38
14	Glossary and terms	38

Index

	Page
14.1 Short cuts	38
14.2 Signals	38
14.3 Terms	39
15 Technical data	40
15.1 Dimensions - Systemdesign	42
18 Trouble shooting	43
18.1 Trouble shooting Collamat 3600	43
18.2 Trouble shooting checklist	48
Appendix Spare parts Collamat 3600	

1 Safety advices

1.1 Important Warnings



Before installing and operating the Collamat 3600 read following safety instructions:

- The labeler C3600 is exclusively determined for labelling goods.
- The installation of a Collamat 3600 has to be done by a trained specialist.
For this you have to consider the national specific regulations of
 - prevention of accidents
 - mechanical stability
 - construction of electrical and mechanical systems
 - noise suppression
- Take notice to the technical data of the Collamat 3600. Especially the environment conditions must be observed.
- The operation of the Collamat 3600 must be done by trained personnel.
- In case of non-authorized modification guarantee will fall.
- Before connecting non-standard products ask your competent technical supporter.

1.2 Danger Indications

- The safety symbols and danger advices on the Collamat 3600 and in this manual must strictly be observed.
- Before connecting or disconnecting the labeler to or from the main, it must be switched off.
- The labeler C3600 may only be opened by authorized personnel.
- Before opening the labeler C3600, it must be separated from the main power.
- It exists danger of pinching hairs, jewelry, ties, clothes etc. into the traction unit
- It exists danger of injury by cutting fingers in the area of the paper web.
- It exists danger of injury in the area of the dancer of the unwinder of the Collamat 3600.
- It exists danger of injury in the area of the paper stockcontroller of the Collamat 3600.
- For operation on the Collamat 3600 the operating personnel must keep to a safely place to prevent injury from the products being labeled.

1.3 Symbol descriptions



ATTENTION

Indicates danger of damaging the Collamat 3600 or other system components, with a potential consequential danger of injuries.

DANGER

Indicates an immediate hazard for persons.

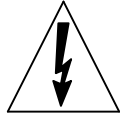

DANGER

Shock hazard due to high voltage at component.



DANGER

Hazard due to high temperature component.



ATTENTION

ESD warning (Electro Static Discharge). The PC boards or component may only be touched in an electrostatically protected environment.

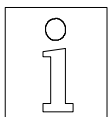

NOTE

Important or additional information to Collamat 3600 or to the documentation.

2 Introduction

2.1 General informations

This technical handbook describes the construction and the function of the Collamat 3600. In addition to the operating instructions, it contains the necessary tips and adjustments to get optimum use of the Collamat 3600. The descriptions of each electrical or mechanical device also helps for quick error analysis and error elimination.

We recommend you to replace the complete electronic boards. Return it to Collamat Stralfors AG or to its representative for repair. You can then feel sure, that the high quality standard of the Collamat 3600 can also be guaranteed after repair.

2.2 The labeler C3600

Special characteristics of the Collamat 3600:

- resistant to wear, no clutch/brake-system
- robust, stable
- easy installation and operation due to the modular construction
- quick change-over to other labelling tasks
- high performance
- high reliability
- latest SMD-technology
- high precision 2-phase steppermotor

The traction unit as well as the other peripheral assemblies are mounted on a modular rail. The control electronics of the peripheral units are built in the units. The units are controlled and driven by signals of the bussystem inside of the modular rail.

The operating elements for dispensing speed, predispensing, optical label scanner, as well as the mains switch are placed right on the body of the traction unit itself. All parts are corrosion-proof, the feedroller of the traction unit is provided with a special coating for permanent nonslip torque transmission onto the paperweb. The rewinding force of the rewinder as well as the braking power of the paper brake are adjustable at the traction unit from the outside.

The installation of the Collamat 3600 must be done by trained personnel. For this you have to consider the national specific regulations of:

- prevention of accidents
- noise suppression
- mechanical stability
- construction of electrical and mechanical systems

2.2.1 Prevention of accidents

While installing and connecting the Collamat 3600 take care that the signal cables and power cables can't become obstacles. The cables must be placed and installed according to the national safety requirements. Take care that the signal cables are not placed beneath power cables.

The power switch and the control elements must easily be accessible.

2.2.2 Noise suppression

The dispenser C3600 is shielded according to the CE directives. Only cables which are certified by Collamat Stralfors AG may be used for connecting the dispenser to the peripheral units and the mains power. Additional peripheral units must be connected to the auxiliary mains terminal of the dispenser. These assemblies must be certified by Collamat Stralfors AG.

2.2.3 Mechanical stability

If the Collamat 3600 is used on a movable stand, this stand must be capable to be tilt 10° in each direction. See also following figure 1:

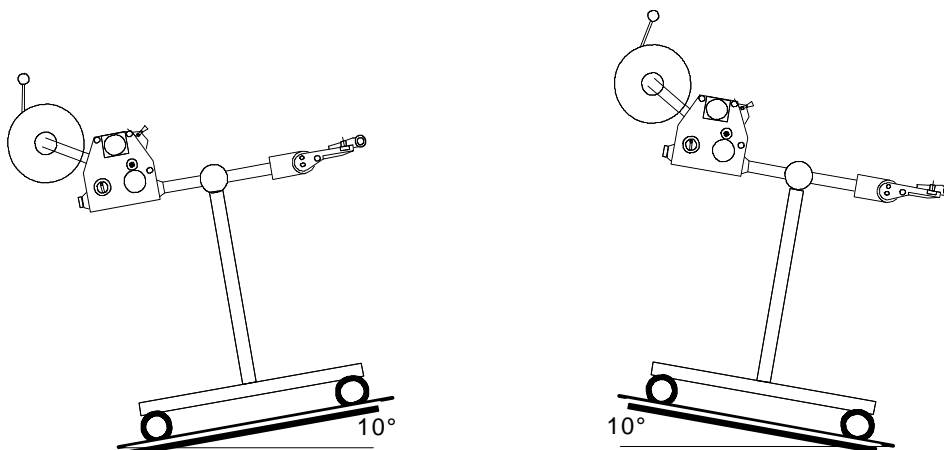

Figure 1: Stability of the stand

2.3 Assembly parts

The assembly parts are mounted and placed on a modular rail. Following figure 2 shows these assembly parts with their names on the modular rail:

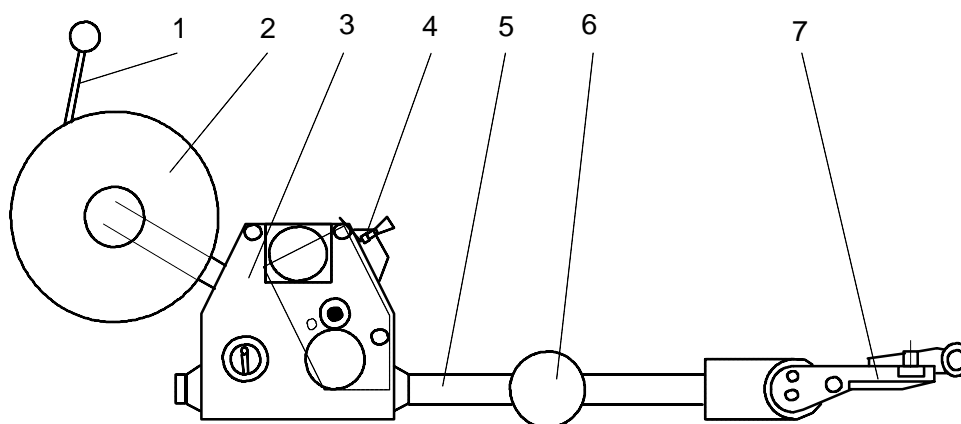

Figure 2: Assembly parts

Legend

- | | |
|--------------------|-----------------------------------|
| 1. Unwinder dancer | 5. Modular rail |
| 2. Unwinder | 6. Support |
| 3. Traction unit | 7. Adapter (optional with magnet) |
| 4. Paper brake | |

3 Mechanical adjustments

3.1 Traction unit

3.1.1 Threading the labelweb

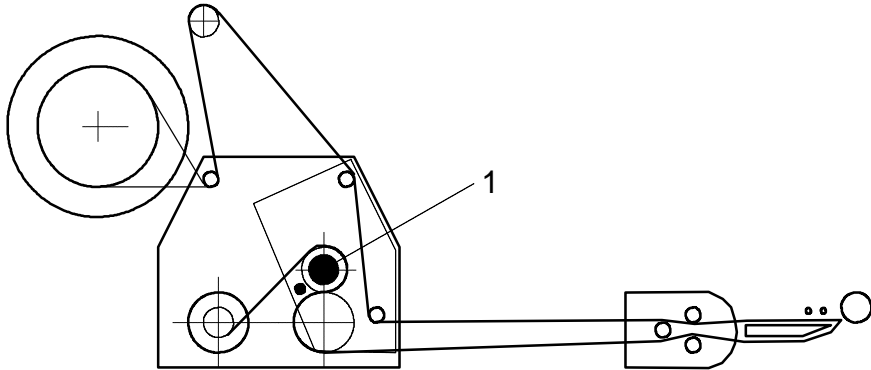

Figure 3

Thread the labelweb as shown in figure 3 up to the dispensing edge and draw it out by approx. 1 m. Detach the labels from the paperweb at the drawn-out web. Then open the pinchroller by turning the knob (1), place the paperweb over the dispensing edge and finish threading the paperweb as shown in figure 3. Close the pinchroller. Adjust the side guides of the paperweb well, leaving 0.5 mm free space to the paperweb's edge.

3.1.2 Adjustment of rewriter coupling force

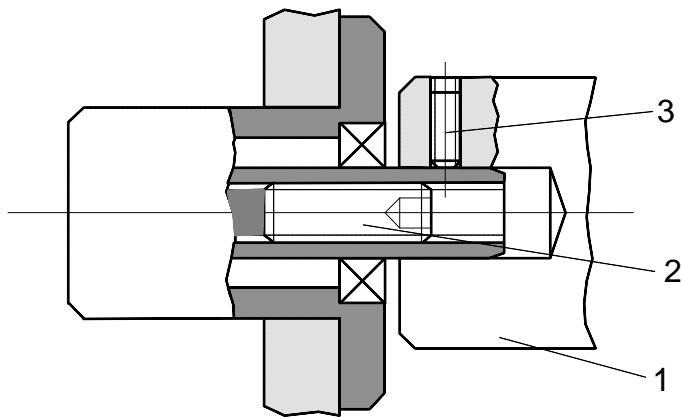

Figure 4

The coupling force of the rewriter is factory-set. Proceed as follows if out of adjustment: Detach winding spindle (1) after unscrewing the M5-bolt (3). Screw M8-bolt (2) accordingly:

- in= harder coupling
- out= softer coupling

3.1.3 Readjustment of paper brake

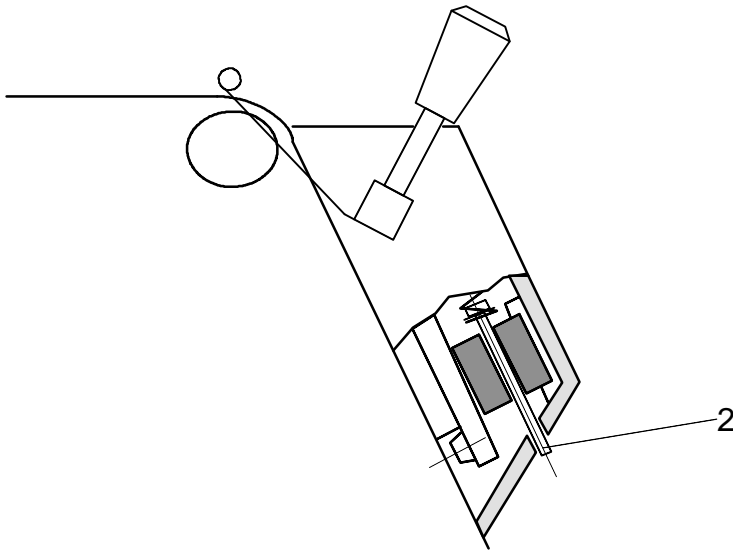

Figure 5

The braking force is factory-set to an optimum value. Should it, however, be unadjusted, readjust it with the M3-bolt (2) in the web-end controlbox of the traction unit, from the outside.

- Screw in bolt= higher braking force
- Unscrew bolt= lower braking force

3.1.4 Longitudinal adjustment on the module rail

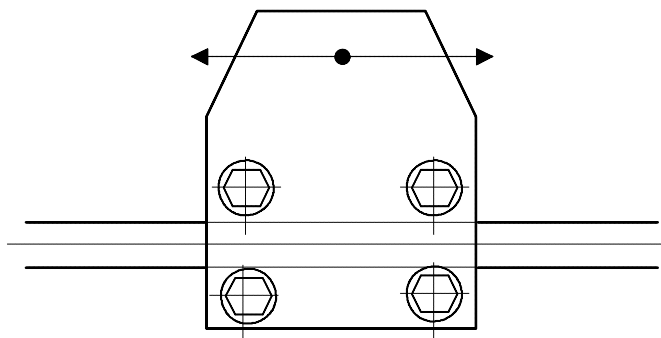

Figure 6

Unscrew 4 bolts with special tool (wrench for socket head cap screws 5 mm) one half turn (adapter only 2 bolts).

Move device, observing scale on module rail. Then tighten bolts equally.

3.2 Flap adapter

3.2.1 Inclination adjustment of flap adapter

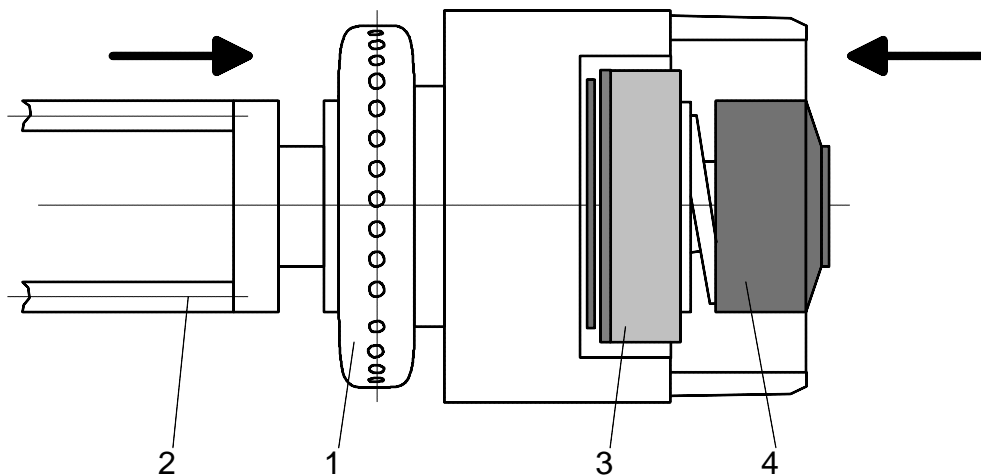

Figure 7

The inclination of the flap adapter can be changed against the module rail: unscrew nut (1) with two turns (refer to figure 7), with special hexagonal spanner (included as accessory). Push adapter in the direction indicated by the arrow (2), turn to desired setting at ring (3). Retighten nut (1).

The pressure force of the flap adapter without magnet or of the magnetic flap adapter is variable: push in button (4) in the direction indicated by the arrow, twist for appropriate spring tension and adjust until it meets the next stop.

3.2.2 Adjustment of the pressure roller of the flap adapter

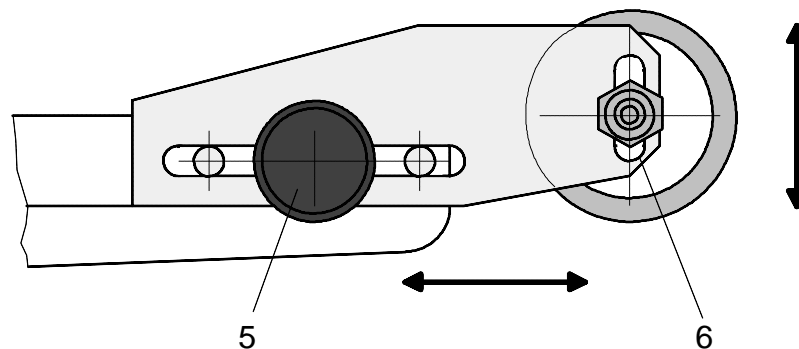

Figure 8

The pressure roller of the adapter can be adjusted depending on the labels and goods:

- Horizontal adjustment with the knurled nut (5)
- Vertical adjustment with the hexagonal nut (6)

3.3 Adjustment of the optical label scanner

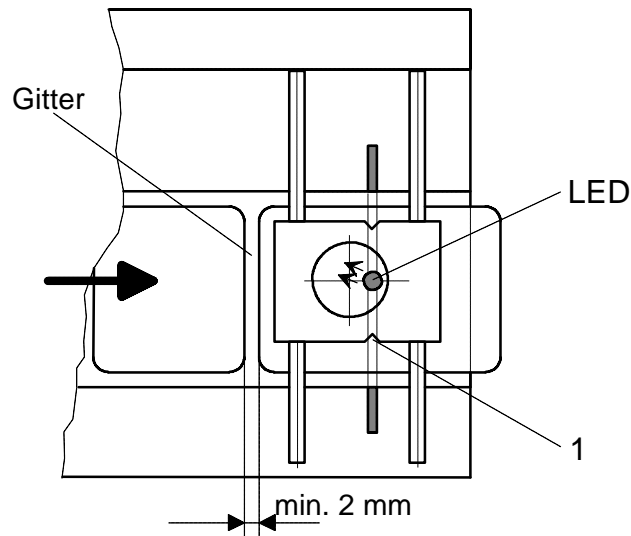
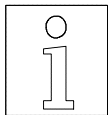

Figure 9

Proceeding of the adjustment of the optical label scanner:

Switch on the Collamat 3600. Set the label scanner potentiometer to zero. Pull the labelweb so that the gap is located below the marking 1 of the scanner. Turn the potentiometer until the red LED on the scanner goes off. Continue pulling the labelweb until a label is located below the scanner. Continue turning the potentiometer until the LED switches off again. The optimum setting is at the center position of the two potentiometer settings witch turned the LED off.



Remark:

If the setting of the optical label scanner is faulty, the gap between the labels will not be detected. After the triggering of a labelling operation, the labeler will stop after approx. 0.75 m of the labelweb.

For transparent labels, please use the mechanical label scanner.

3.4 Adjustment of the mechanical label scanner

The mechanical label scanner (not used on magnetic flap adapter) is an alternative to the optical label scanner and is mainly used for transparent labels.

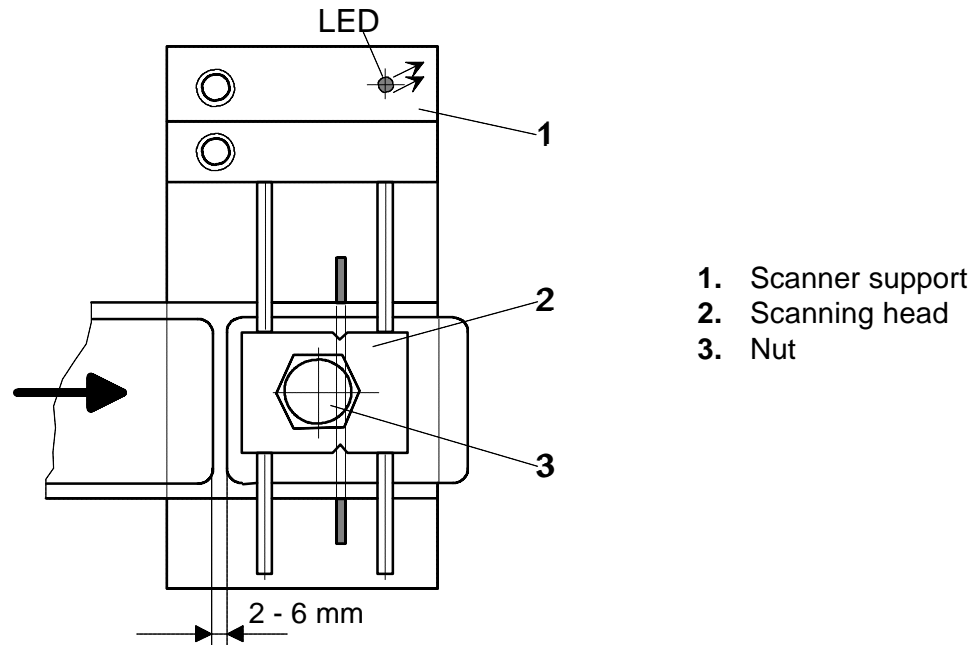
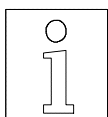

Figure 10

Adjustment:

- Place the label under the scanning head, the LED on the scanner support must be turned on. If this is not the case, unscrew the nut on the scanning head and turn it counterclockwise until the LED turns on.
- Turn the scanning head clockwise until the LED turns off.
- Turn the scanner one quarter turn forward and retight the nut.
- Place the gap between the labels under scanning head, the LED-display must be turned on.



Note:
No adjustment is necessary on the traction unit!

4 Technical description

4.1 Dispenser board

All the electronic devices including power transformer, except of the main switch with indicator lamp, are located on a printed board. The dimensions of the board are approximately 215 x 234 mm. Figure 11 shows the board with all the connectors and terminals.

The description is divided into power supply, motordriver, controller and firmware.

4.1.1 Power supply

The power supply unit generates the two regulated voltages +12 V/1A and + 5 V/1 A for the logic, as well as an unregulated DC voltage of approx. 40 V/3.5 A for the stepper motor. The stabilization is done by linear voltage regulators.

4.1.2 Motordriver

The driver board consists of 2 H-bridge circuits to drive the two motor phases. The phase current is 4 A while running, and 2 A when stopped. To control the current, a chopper circuit with 20 kHz chopper-frequency is used.

Dependent on the dispensing speed the processor generates a fullstep- or a halfstep pattern. For speeds faster than 10 m/min, the motor is driven by a fullstep- pattern.

In the case of overheating, short-circuit or malfunction the motordriver is switched off and the red LED **FAULT** is illuminated. In this case the labeler must be switched off and on again.

4.1.3 Controller

The single chip micro-controller H8/532 with external 32 K-Byte EPROM controls the functions of the labelling process.

- All outputs are buffered by photo-couplers.
- All the inputs are pulled up to +12V with 2.2 K and are equipped with a low-pass filter.
- The A/D-converter scans periodically the value of the settings of the 3 potentiometers (R101....R103).
- The control current of the label scanner is generated by a controlled current source.

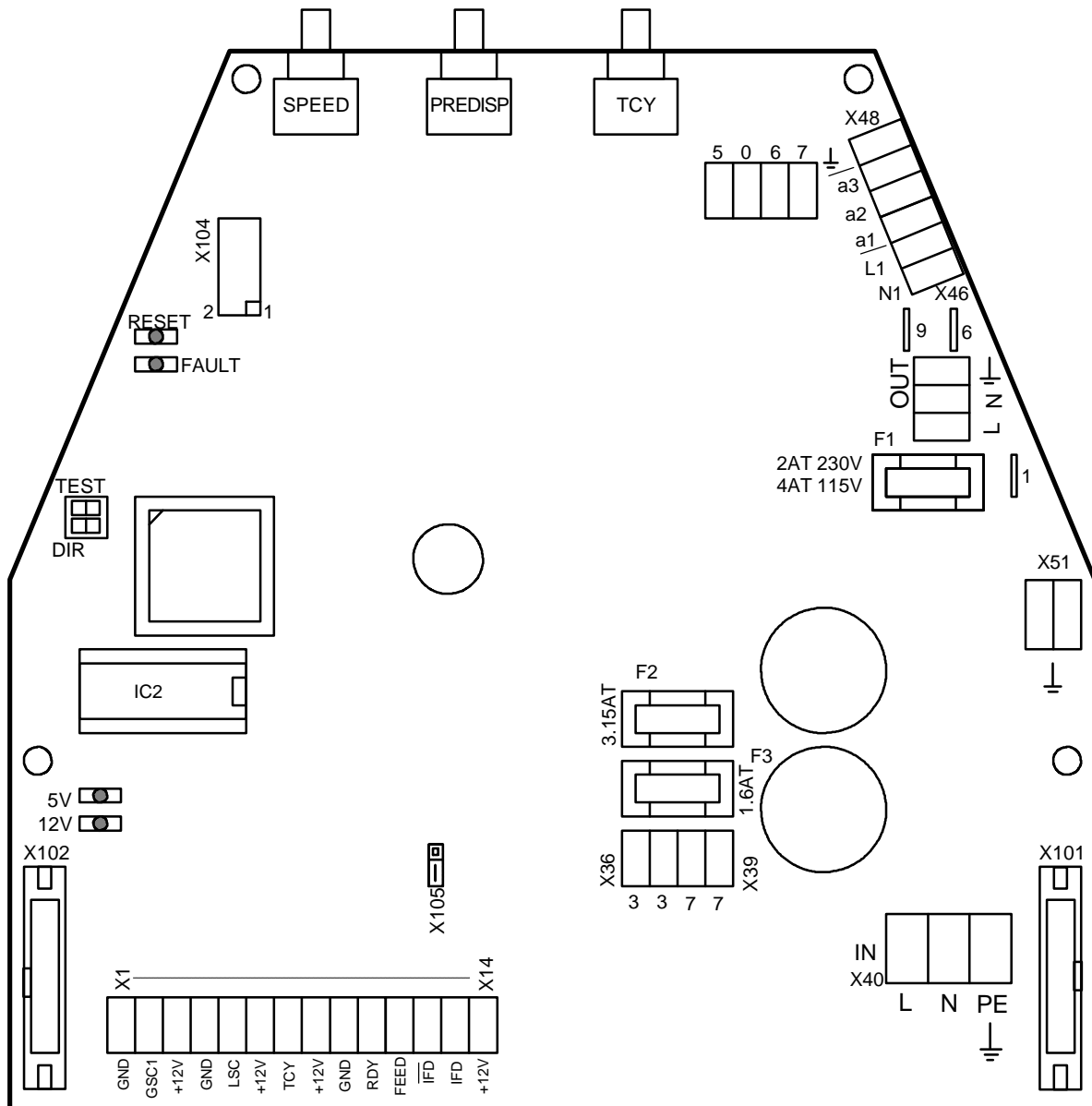

Figure 11: Dispenser board

4.2 Signals and connection diagrams

All in- and outputs are equipped with filter elements to prevent electromagnetic interference. These components also prevent interference caused by electrostatic discharge. The interference can lead to malfunction of the Collamat 3600. Anyway, installing the Collamat 3600 you have to consider the rules concerning RMI and ESD to prevent these interferences. See also chapter **Cabling**.

4.2.1 Inputs

The inputs are used to connect peripheral units and sensors. The inputs are activated while they are pulled to GND (0 Volt). The peripheral units from Collamat Stralfors AG have NPN-outputs to 0 Volt.

Figure 12 shows the schematic diagram of the inputs:

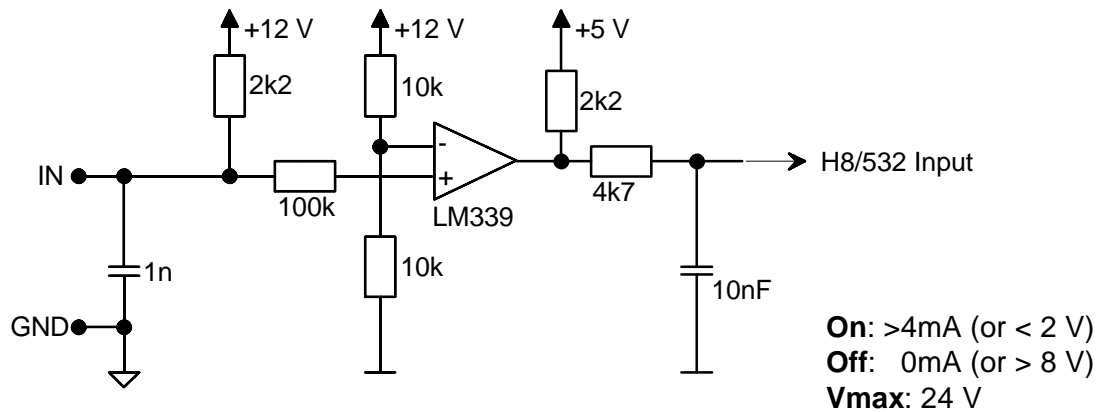

Figure 12: Signal input

An input is then active, when a current of minimum 4mA is pulled to GND. The following inputs are available:

- **GSC1** Goods scanner
- **LSC** Label scanner
- **READY READY**-signal for peripheral units

4.2.2 Outputs

The outputs are used to control peripheral units. There are three different kinds of outputs:

- **Isolated output**
- **Open-Collector-output**
- **Currentsource-output**

4.2.3 Isolated output IFEED

This output is completely isolated to the electronic circuit of the labeler. Figure 13 shows the schematic diagram of this isolated output:

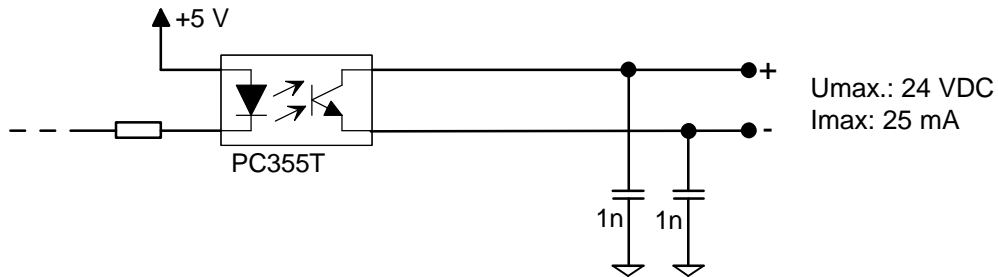

Figure 13: Isolated output IFEED

4.2.4 Open-Collector-output IFEED

For better resistance against interferences, the Open-Collector-output **IFEED** is also equipped with a photocopler. Figure 14 shows the schematic diagram of the Open-Collector-output **IFEED**:

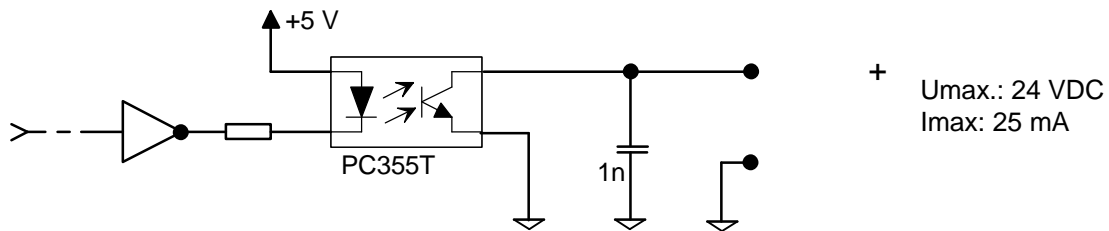

Figure 14: Open-Collector-outputs

4.2.5 Currentsource-output

For the IR-transmitter of the label scanner **TCY**, a controlled currentsource is used. Figure 15 shows the schematic diagram of the currentsource:

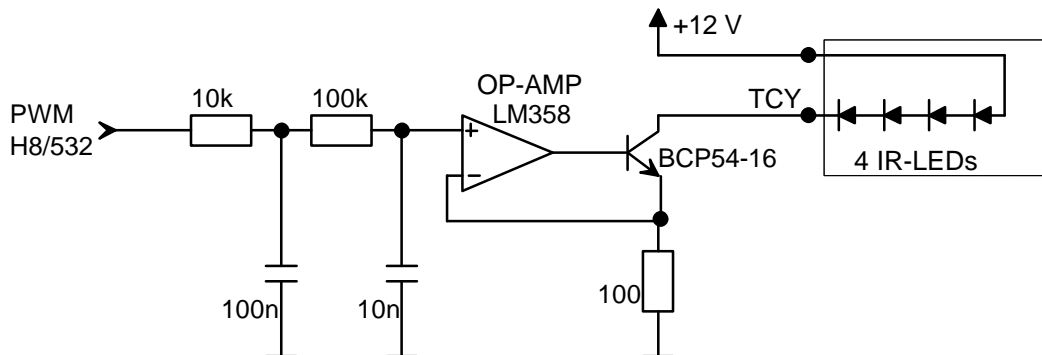

Figure 15: TCY-currentsource

4.3 Connection diagrams BUS X101, X102

The busable of the peripheral units is connected to the connectors X101 or X102. The cable must be placed inside of the module rail to prevent interferences. Figure 16 shows the position of the busable connectors on the dispenser board:

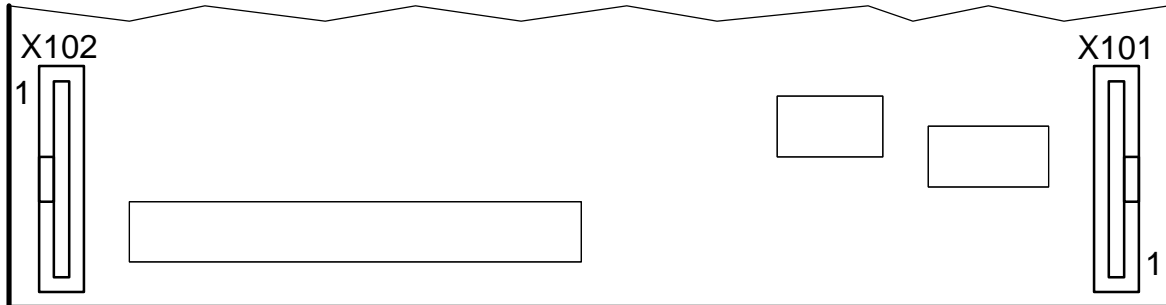
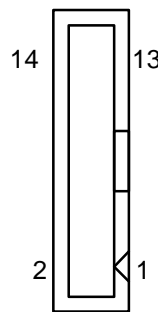
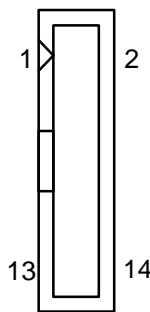

Figure 16

Connector X102			
Pin	Signal	Pin	Signal
1	+12V	2	+12V
3	READY	4	FEED
5	LSC	6	GSC1
7	TCY	8	nc.
9	nc.	10	nc.
11	nc.	12	nc.
13	GND	14	GND



Connector X101			
Pin	Signal	Pin	Signal
1	GND	2	GND
3	nc.	4	nc.
5	nc.	6	nc.
7	nc.	8	TCY
9	GSC1	10	LSC
11	FEED	12	READY
13	+12V	14	+12V

4.4 Transformer wiring

The secondary side of the transformer is connected to the terminals X36...X39. Both **violet** wires are connected to the terminals signaled with a 7. Both **orange** wires are connected to the terminals signaled with a 3. See also Figure 17:

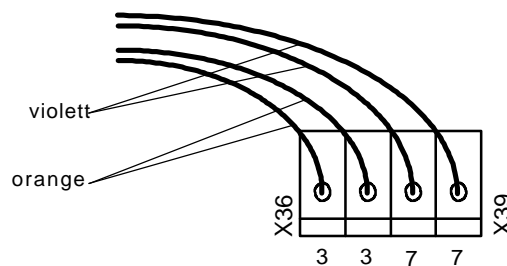

Figure 17

The primary side of the transformer is connected to the terminals X46 and X48. Dependent to the mains voltage the transformer is connected as shown in figure 18:

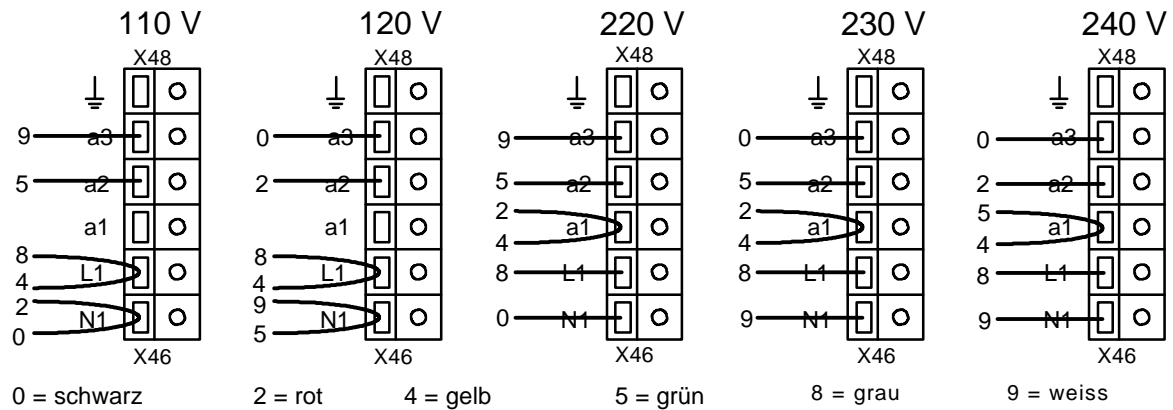

Figure 18: Transformer wiring

4.5 Connection of the mains input

The powercord must be connected to the terminal X40. To prevent interferences it must be looped through a ferrite-filter as shown in figure 19:

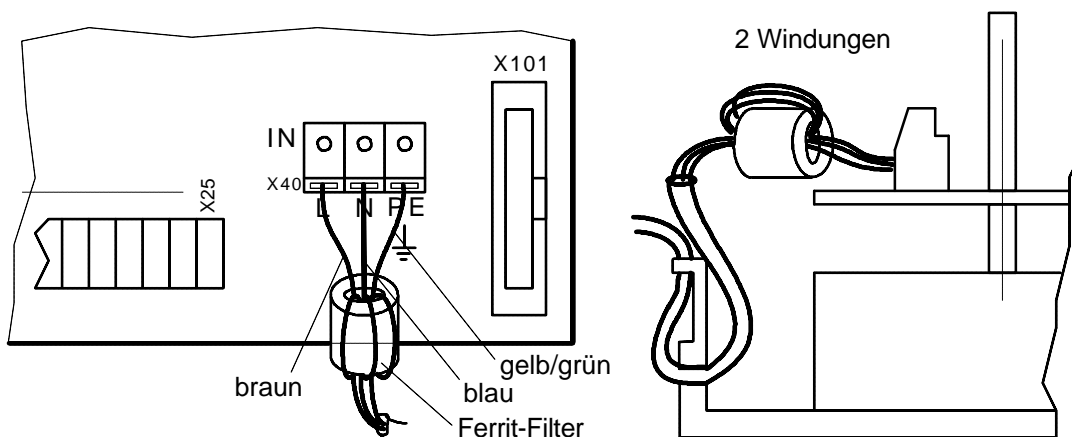

Figure 19

4.6 Grounding of the labeler

The grounding of the module rail and of the adapter must be done to terminal X51. For this see also figure 21.

4.7 Connection of the mains output

Peripheral units like the flatprinter or the adapter with magnet are connected to the mains output. To this terminal only units, certified by Collamat Stralfors AG, may be connected. Figure 20 shows the mains output terminal:

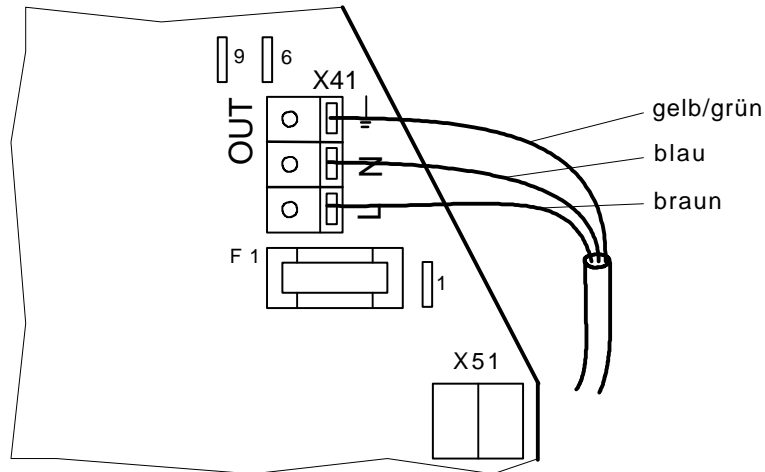

Figure 20

4.8 Connection of the frontpanel

The frontpanel must be connected as shown in figure 21:

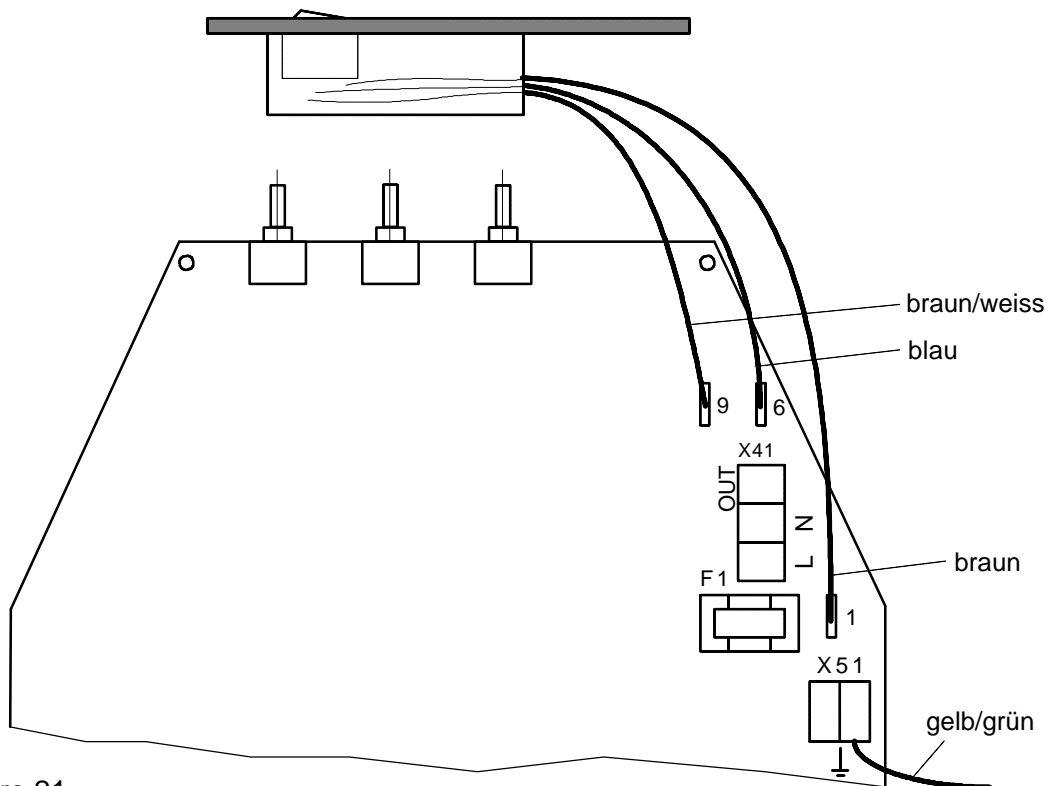

Figure 21

4.9 Motor and motorcable



Attention:

- **The motor never must be dismantled !**
- **Steppermotor heats up during operation !**
- **When connecting or disconnecting the motor, the labeler must be switched off !**
- **While working on the motor, the labeler must be disconnected from mains !**

The motor is connected inside of the labeler. The motorcable is lead through the hole in the middle part of the board. The wires are connected to the terminals X30...X33. See also figure 22:

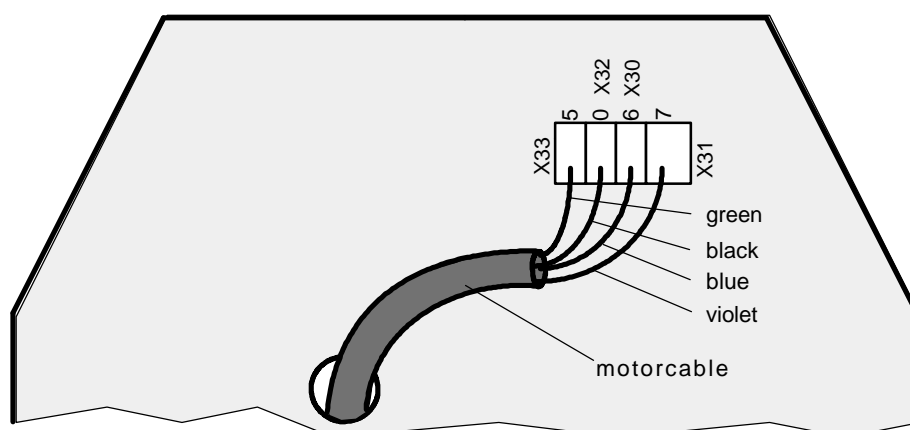

Figure 22: Motor connection

5 Firmware

5.1 Normalmode

After turning on the labeler, the DIL-switches are scanned to figure out the working mode. The dispensing of a label is triggered by the negative edge of GSC1 (Goods scanner input). READY must not be active (12 Volt). The stop of the labelling is triggered by the detection of the gap (LSC) and performing the remaining steps for the predispsensing. The timing diagram of the signals is shown in figure 23:

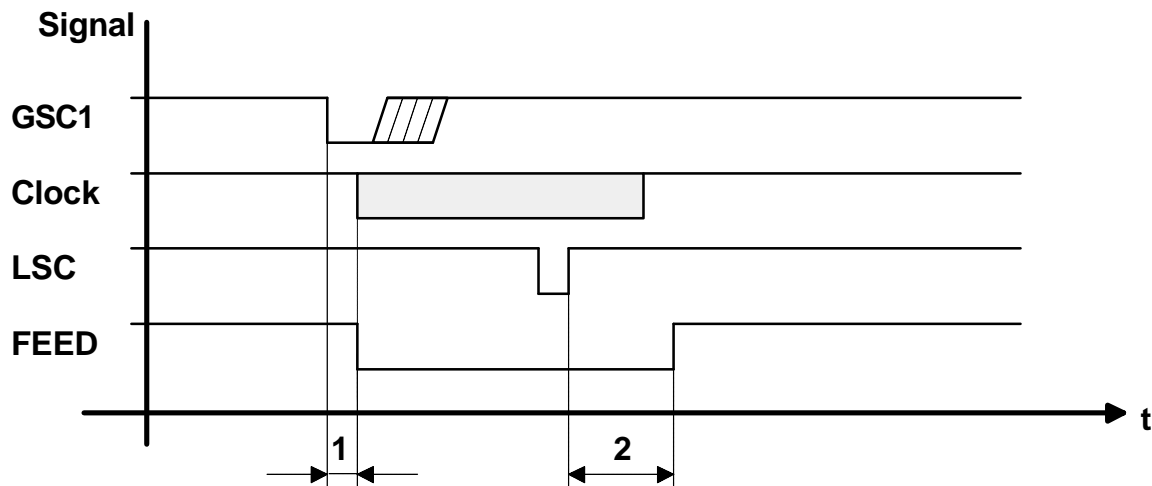

Figure 23: Timing diagram of the GSC1, LSC and FEED signals

1. Speed dependent position delay
2. Length of the predispsensing

If the predispsensing is increased, it is executed immediately. If it is reduced, it is executed after dispensing the next label.

To generate the holding torque, the motor is powered all the time.

If, for any reason, no negative edge is detected on the LSC-input, the labelweb is automatically stopped after approximately 2 meters.

At speeds faster than 10 m/min, the steppermotor is driven in the fullstep-mode. For slower speeds, in the halfstep-mode.

The minimum speed is 3 m/min. The maximum speed is 20 m/min.

5.2 DIL-switches

The dispenser board contains two DIL-switches. These switches are used to select different operating modes. The following table and figure 24 show the functions and the positions of the DIL-switches:

Switch	Function	Off	On
TEST	Labelingmode/ Testmode	Labelingmode	Testmode
DIR	Turning direction of the motor	Right	Left

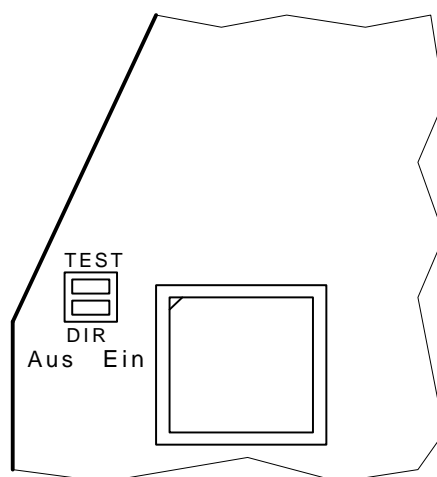

Figure 24: DIL-switches

5.2.1 DIL-switch TEST

This DIL-switch selects the testmode. For further informations to the testmode, please read the chapter **Testmode**.

5.2.2 DIL-switch DIR

This DIL-switch selects the turning direction (right or left) of the traction motor.

6 Trouble shooting

6.1 Fuses

The Collamat 3600 contains three fuses:

Fuse	Voltage	Value	Part. No.
F1 110V: 230V:	Mains voltage	4AT 5*20mm 2AT 5*20mm	74030800 74030341
F2	Motordriver 40V	3.15AT 5*20mm	74031216
F3	Logic 12 V, 5V	1.6AT 5*20mm	74031135

To exchange the fuses, the cover of the Collamat 3600 must be removed.

If the fuse of the main voltage is blown, the indicator lamp of the power switch is not illuminated when the Collamat 3600 is switched on.

If an external peripheral unit like flatprinter or flap adapter is working without any movement of the traction motor, F2 seems to be defective.

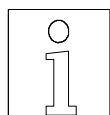

ATTENTION:

If the dispenser board is defective, it must be exchanged. Any repairs or modifications not made by Collamat Stralfors AG will expire the guarantee.

6.2 Status LEDs

The four status LEDs on the dispenser board display show different signals:

LED	Function	Fault
5V	Illuminated, when the 5V for the logic circuit are OK	Fuse F3 or F1
12V	Illuminated, when the 12V for the sensors are OK	Fuse F3 or F1 Short circuit in the sensor supply
RESET	Flashes while turning power on Flash while running	Watchdog RESET Software failure
FAULT	Motordriver supervision	Overheating, short circuit, undervoltage, fuse F2

For trouble shooting, please use the checklist on the last page of the handbook.

7 Peripheral units and sensors

7.1 Optical label scanner

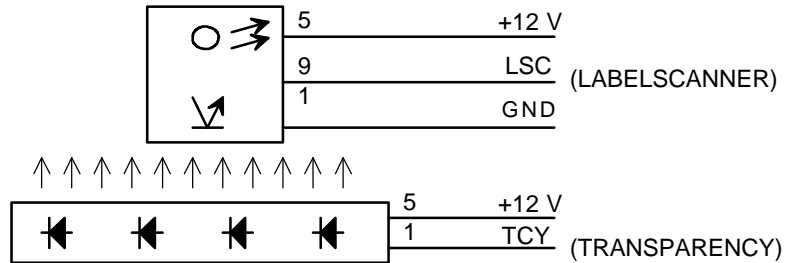

Figure 25

7.2 Goods scanners

7.2.1 CS measuring IR-scanner

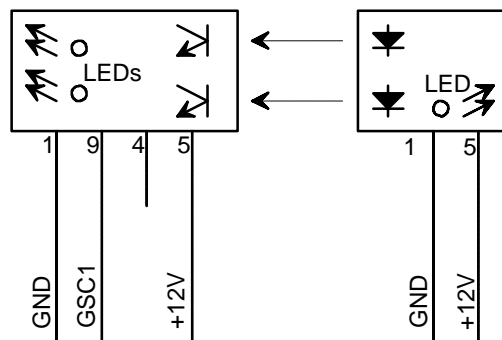

Figure 26

7.2.2 NPN-Reflective scanner

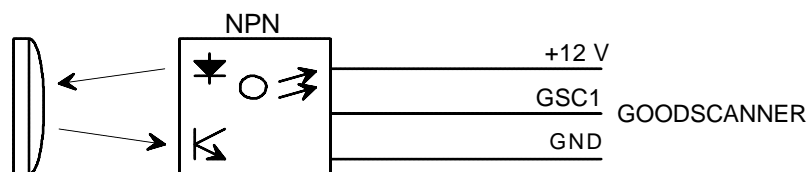

Figure 27

7.3 Magnet adapter

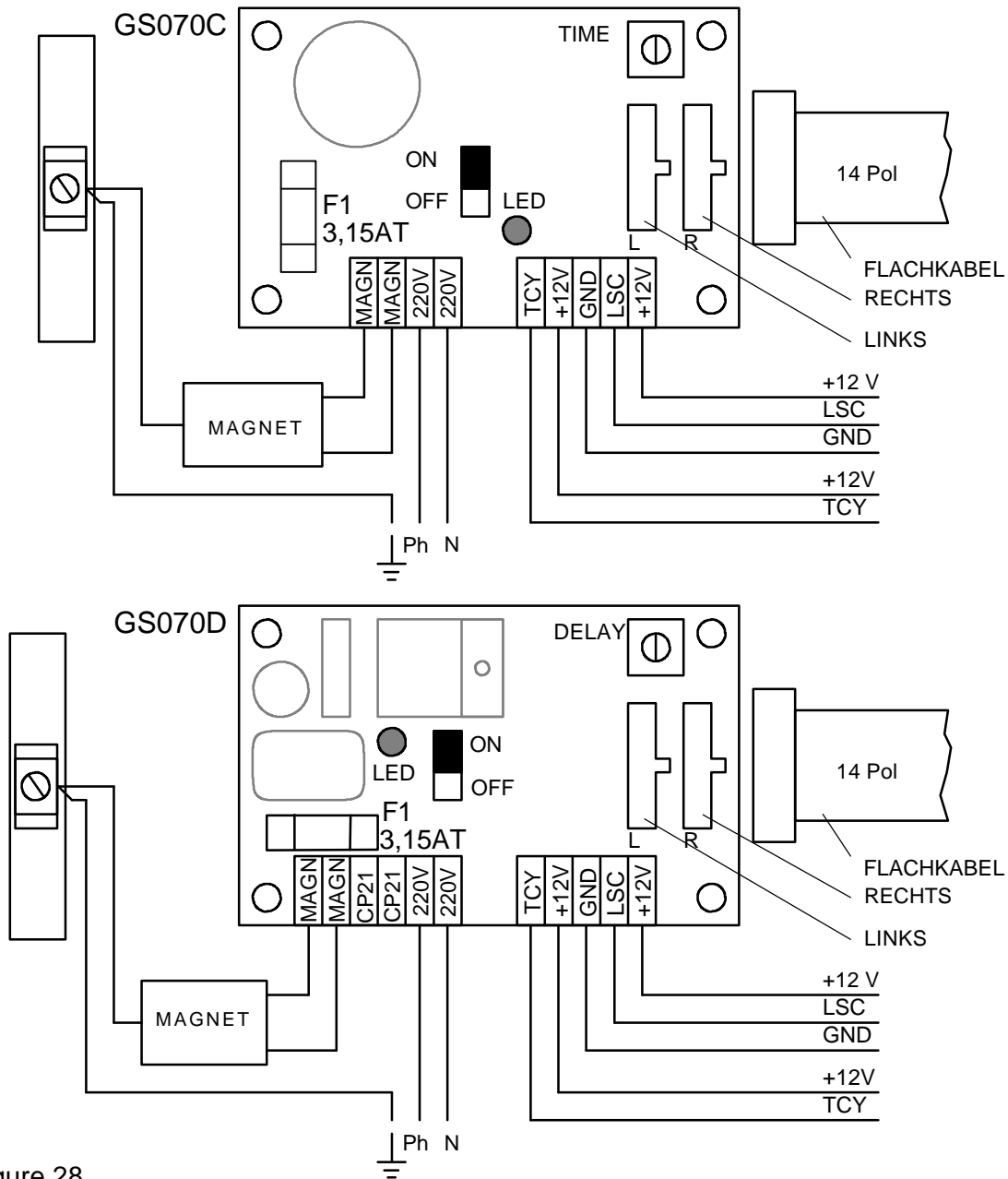

Figure 28

The mains voltage must be connected inside of the flap printer or inside of the dispenser.

The factory setting of the trimmer TIME is on MINIMUM. The trimmer is used to set a delaytime for the releasing of the magnet.

The terminals CP21 are used to connect the synchronous motor of the wrap around adapter



WARNING:

Plugging in of the LEFT or RIGHT connector of the flatcable to the wrong plug can damage the magnet adapter board.

7.4 Flatprinting unit
7.4.1 Flatprinter board

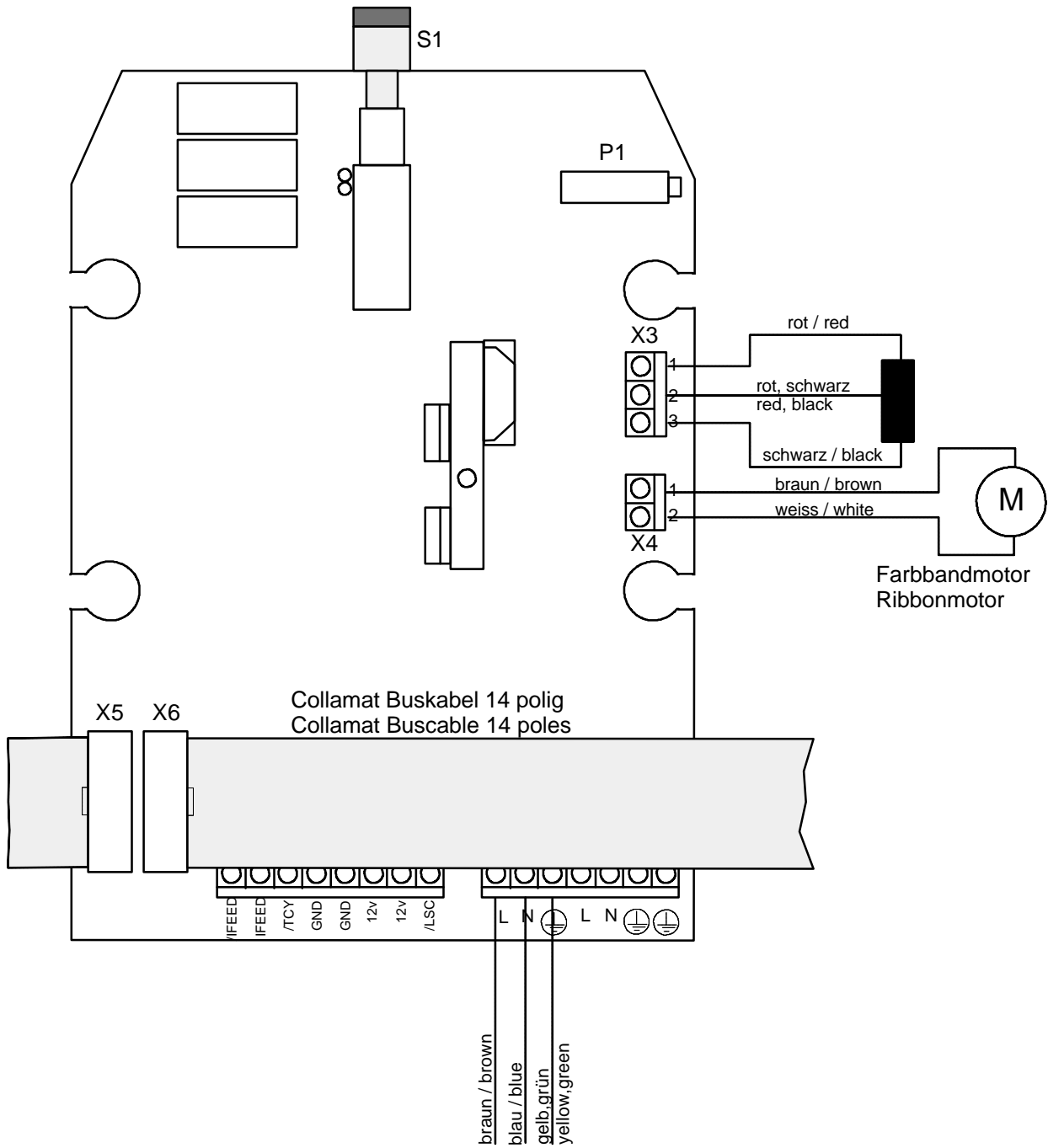

Figure 29

8 Control signals for external units

The signals **FEED** and **READY** are used to control external units.

FEED (Output)

The **FEED** signal indicates that the labeler is dispensing. This means that the stepper motor is turning. With this signal an external flatprinting unit can be controlled. See herefore figure 23.

READY (Input)

The signal **READY** is used to signal that a connected peripheral device like hotstamp or flat-printer is ready. If the signal is active, this means the NPN-output of the device is pulled to GND, labelling is not possible.

8.1 How to connect a goods scanner

The goods scanner is connected to the GSC1 terminals. Figure 30 shows the connection of the standard Collamat Stralfors AG IR goods scanner:

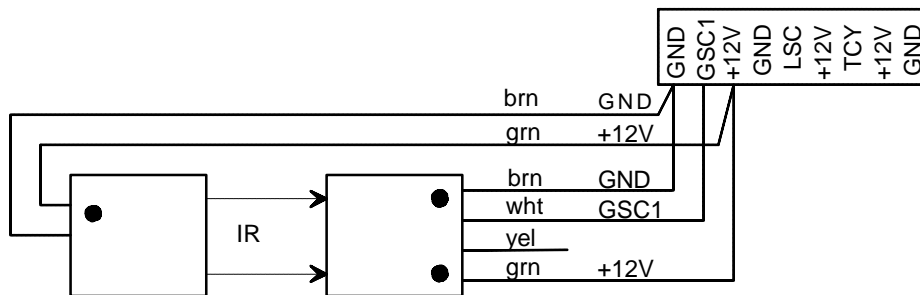

Figure 30: Connection of the CS IR goods scanner

Figure 31 shows the connection of a NPN-scanner:

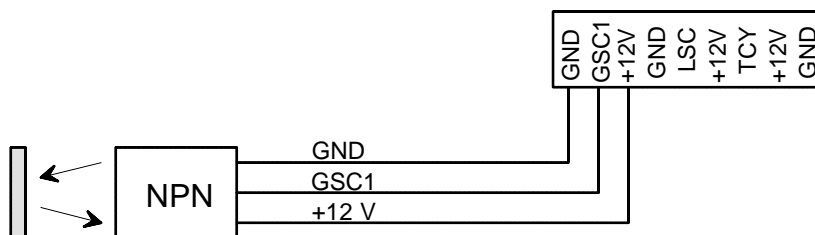

Figure 31: Connection of a NPN-scanner

9 Electrical installation

9.1 Introduction

The cabling must be done like shown in figure 32. The control signals FEED and READY, the supply +12 Volt and ground, are fed through the 14 pole flatcable to the flatprinter and the magnet adapter. An additional 3 pole power cable (3 x 0.75 mm²) feeds the switched mains voltage from the Collamat 3600 to both peripheral units.

The transmitter (2 pole cable) and receiver (3 pole cable) of the optical label scanner can directly be connected to the dispenser C3600, to the flap adapter or to the flatprinter respectively. In this case, the connection to the Collamat 3600 is made by the 14 pole flatcable.

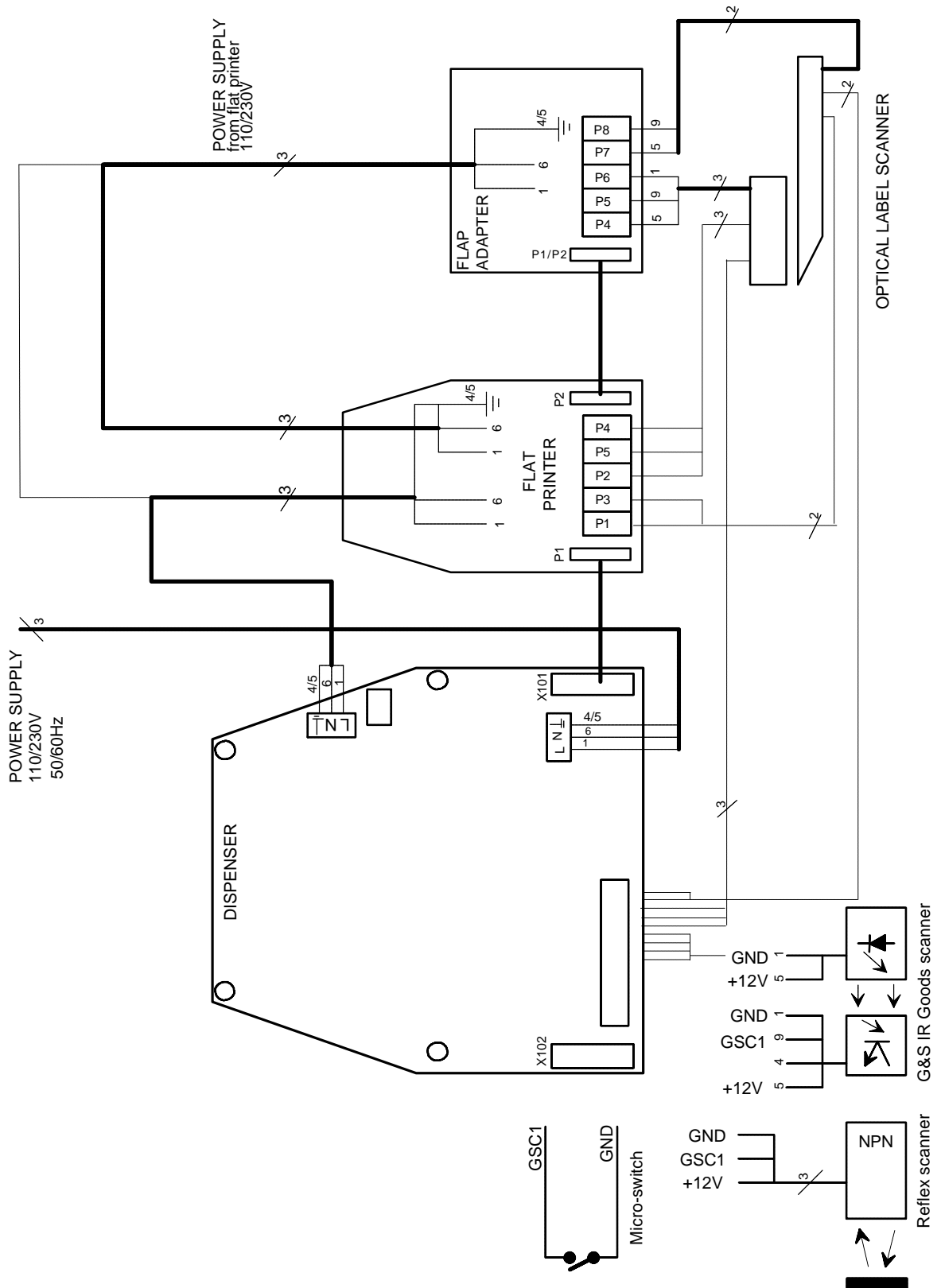

Figure 32: Connection diagram

10 Testmode

The firmware of the Collamat 3600 has a standard test and diagnostic routine. If the DIL-switch TEST is switched on while turning the power on, the firmware starts the test and diagnostics routine. See also figure 24.

In the testmode, the motor is started and stopped periodically with the speed, set on the SPEED potentiometer. If there are any labels threaded through the Collamat 3600, the labels will be dispensed periodically.

In the testmode, the Collamat 3600 can be controlled by an ASCII-terminal or a PC with a terminal emulation software. The communication with the Collamat will be done through the connector X104 using the RS232 protocol. The test software is menu driven and self explaining. The user language is English.

To communicate with a PC, a serial communication cable is used. The figure 33 shows the electrical connections of the serial cable:

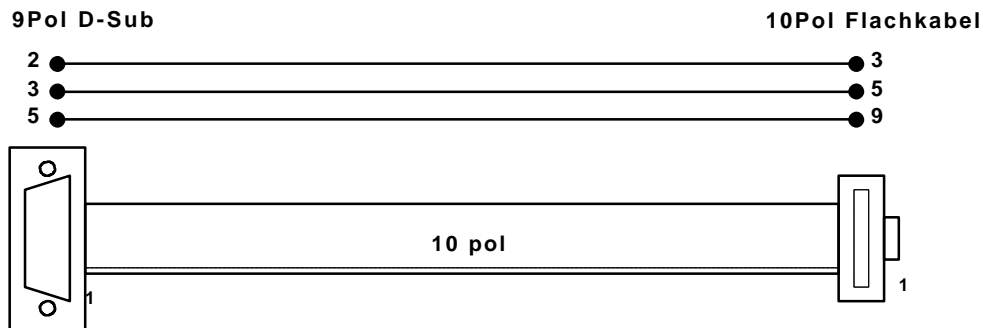

Figure 33

Communication parameters	Terminal settings
9600 Baud, 8 Bit, 1 Stop Bit, No Parity	TTY, Text

Figure 34 shows how to connect the Collamat 3600 to a PC:

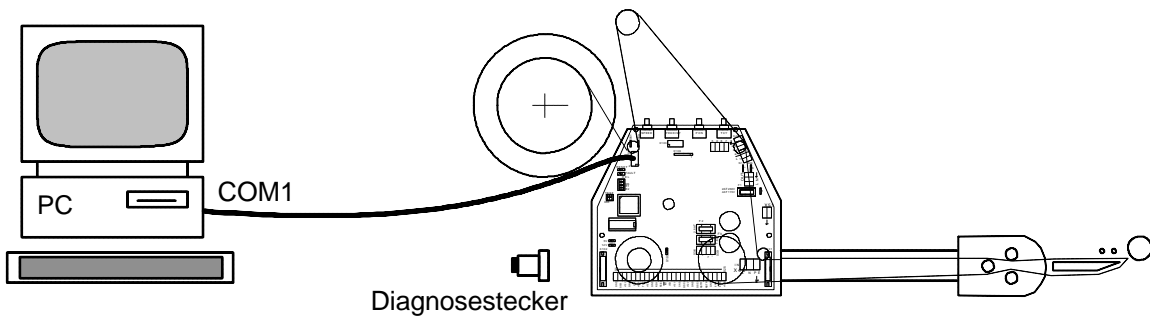

Figure 34: Test connections

10.1 Test software

When the Collamat 3600 is connected to the terminal, it must be switched on. At this moment the DIL-switch TEST must be set to on. The traction unit begins to turn with the speed set on the SPEED potentiometer. The terminal shows the following message:

```
COLLAMAT 3600 V1.01

Motor intervall test. Use spacebar to leave
```

Pressing the spacebar stops the motor intervall test. Now the following help menu will be displayed:

```
Helpmenu for C3600 Testprogram
-----
H : Help
M : Motortest
N : Motor intervall test
B : BUS-signal selftest
S : Signals display
D : DIL-switch settings
P : Potentiometer settings
V : Firmware Version

Select Testfunctions with the Keys H,M,N,B,S,D,P,V
>
```

The testfunctions can be called with the appropriate keys. All testfunctions can be stopped with the spacebar.

10.1.1 Motortest

The **Motortest** is used for measuring the phase currents of the motor. The motor turns with the speed set on the SPEED potentiometer.

```
>m
Motortest. Use spacebar to leave
```

10.1.2 Motor intervall test

The **Motor intervall test** tests the labelling functions of the Collamat 3600. If a label web is threaded through the dispenser, labels will be dispensed periodically with the speed set on the SPEED potentiometer.

```
>n
Motor intervall test. Use spacebar to leave
```

10.1.3 BUS-signal selftest

The **BUS-signal selftest** tests all in- and outputs of the Collamat signalbus. For this test a diagnostic connector (see figure 35) must be plugged into the busconnector X102 (left side).



Attention:
To avoid damage of peripheral units or sensors, all sensors and bus- cables must be removed from the connectors.

```
>b
BUS-signal selftest
Testing FEED+LSC.....OK
Testing FEED+READY....OK
Testing TCY+GSC1.....OK
```

This test will display faulty signalpairs on the terminal screen. If the test is started without the diagnostic connector the following message is displayed:

```
>b
BUS-signal selftest
Testing FEED+LSC.....not OK !
Testing FEED+READY....not OK !
Testing TCY+GSC1.....not OK !
```

Figure 35 shows the schematic diagram of the diagnostic connector:

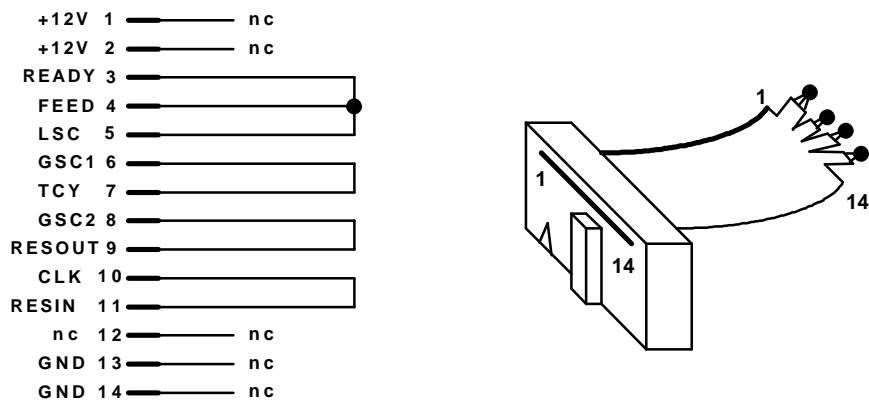

Figure 35: Diagnostic connector

10.1.4 Signal display

This test displays the levels of the input signals. It is used to test the function of the sensors and input circuits.

```
>s
Signals display. Use spacebar to leave
GSC1  READY  LSC   FAULT
OFF   OFF    OFF   OFF
```

10.1.5 DIL-switch settings

This test shows the position of the DIL-switches. It is used to test the function of the DIL-switches.

```
>d
DIL-switch settings. Use spacebar to leave
TEST  DIR
ON    OFF
```

10.1.6 Potentiometer settings

This test shows the position of the potentiometers. It is used to test the function of the potentiometers.

```
>p
Potentiometer settings. Use spacebar to leave
SPEED  PRE.  TCY
0631   0057  0187
```

10.1.7 Firmware Version

This test displays the firmware version number and its release date.

```
>v
Firmware Version

COLLAMAT 3600
Version   : V1.01
Date      : 28. Nov. 1996
```

11 Control of a hotstamp with the IFEED signal

Two different type of hotstamps (NPN or PNP) can be connected. Figure 36 shows how to connect different hotstamps. Figure 37 shows the timing diagram.

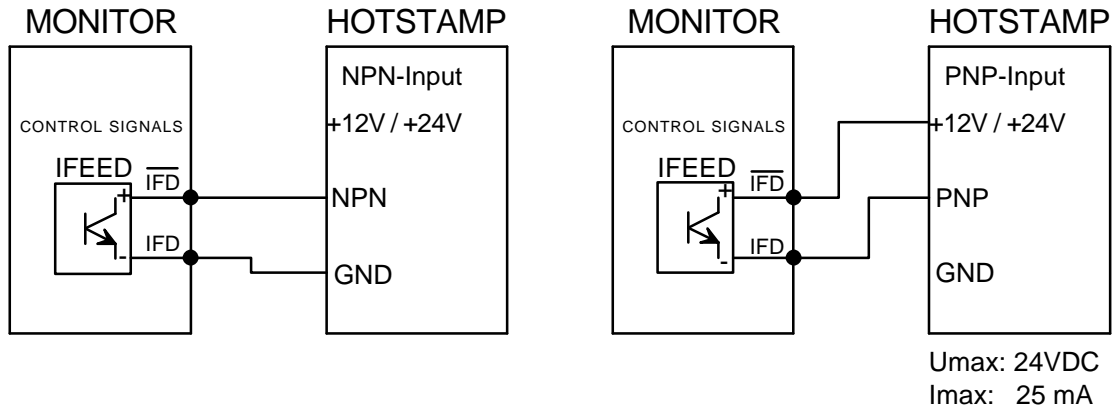

Figure 36: Connection of IFEED

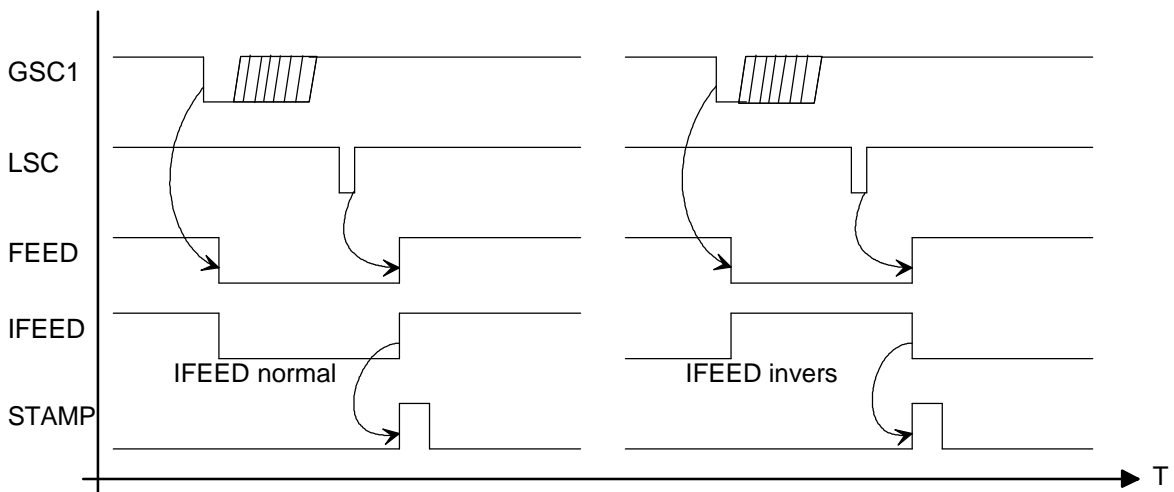

Figure 37: Timing diagram

Dependent to the manufacturer and the model, the polarity of the triggering signal of the hotstamp must be changed. This adjustment is to be set with the jumper X105 on the dispenser board, to **normal** or **inverse**. The position of the jumper X105 can be found on figure 11.

12 Cabling and setting up

For a trouble free operation of the Collamat 3600 following items must be observed:

- Trained personnel
- Ambient temperature
- Absence of dirt and dust
- Absence of splashing water
- Installation and setting up of the installation
- Installation and setting up of the Collamat 3600
- Electromagnetic interferences
- Safety regulations and safety requirements

12.1 Cabling

Electromagnetic interferences can lead to non repeatable and not obvious errors while labelling. Most times misplaced layout of the cabling, RMI and ESD interferences disturb the labelling. Because of this, the following rules must be observed for the cabling:

- Separated mains and signal cables
- Use shielded cables
- All units must be grounded
- Connect only devices which meet the RMI standards
- Use power filters in interfered environments and interfered mains supplies

12.2 Setting up

The setting up must be done carefully by trained personnel. The following items must be observed:

- Visual check of the labeler unit
 - Are all electrical and mechanical units correctly attached ?
 - Are all connectors accessible ?
- Connect the labeler to the mains and switch it on
 - Is the power switch illuminated ?
- Turn off the labeler and unplug it
- Set up the DIL-switches according to the desired mode. Motor turning direction.
- Attach the goods scanner signals to the labeler
- Connect the remaining units to the labeler
- Connect the labeler to the mains and switch it on
 - Do the peripheral units work OK ?
- Thread the paperweb and adjust the label scanner
- Dispense a label. Is it dispensed correctly ?

13 Version numbers

Dispenser board	
Part number	Version
5215.7400A	Basic version from first series
5215.7400B	Second revised version

Firmware		
Version	Date	Characteristics/Modifications
1.00	06. 28. 1996	Basic version from first series
1.01	11. 28. 1996	Correct handling of the READY signal

14 Glossary and terms

14.1 Short cuts

ESD	E lectro S tatic D ischarge
RMI	R adio M agnetic I nterference
GND	G rou N D
IR	I nfra R ed
LED	L ight E mitting D iode
nc	n ot c onnected
RS232	S tandard serial data exchange protocol

14.2 Signals

FEED	Signal indicating the labelling process
GND	G rou N D
GSC	G oods S Canner
IFEED	Isolated FEED signal
LSC	L abel S Canner
nc	n ot c onnected
READY	READY signal from peripheral units
TCY	T ransparen C Y, control current for the label scanner IR-diodes

14.3 Terms

Stopping accuracy: Accuracy of the paper transportation

Unwinder: Device that carries the full paperweb rolls and unwinds it

Adapter: Part of the labeler by which the label is peeled off from the paperweb and applied onto the products

Rewinder: Device that takes the empty paperweb from the traction unit and rewinds it

CE-Mark: Certification for the European market, means: Conformité Européenne

Collamat: Brand name for a labeler built by Collamat Stralfors AG

GSC: Goods Scanner

Flap adapter with magnet: Adapter which moves down to the product during the labelling

LSC: Label Scanner

Position: Sticking position of a label on the good

Predispensing: Predispensing of a label on the peeling plate

Motorstep: Travelling way of the label for one motorstep

Dispensing speed: The speed of the goods to which the labels are sticked

Startfrequency: Highest possible frequency for a steppermotor to start moving without loss of steps

Traction Unit: Part of the dispenser with drive unit and electronic control

15 Technical data

Dispenser general data (standard values)

System	Units	C3610	C3620
Version		right/left	
Dispensing speed	m/min	3.0-20	
Min. label width	mm	10	
Max. width of the paperweb	mm	95	160
Min. label length	mm	10	
Min. label length at max. dispensing speed	mm	20	
Stop accuracy	mm	± 1 mm @ 20 m/min	
Minimal gap for optical scanner	mm	2	
Minimal gap for mechanical scanner	mm	2	
Max. diameter of paperroll	mm	250/350	
Max. weight of paperroll	kg	10	
Noise figure	dBA	< 70	

Traction unit

System	C3600
Driver	2 phase stepper motor, 200 steps
Motor voltage	40 V
Max. phase current	4.0 A
Type of protection	IP40
Ambient temperature	+5-40 °C
Ambient humidity	15-90%, non condensing
Noise figure max.	< 70 dBA, 1 m distance

System	C3610	C3620
Weight	12 kg	14 kg

Midi-unwinder

Diameter of the roll core	42 mm
Max. outside diameter of roll	350 mm
Max. weight of roll	10 kg
Spring dancer with automatic brake	

Flap adapter

System	C3610	C3620
Max. width of paperweb	95 mm	160 mm
Weight	1.9 kg	2.2 kg
Version	right/left	
Adapter angle	±90°, with adjustable snap-in locking	
Recuperating spring force	adjustable	
Additional press time of adapter	adjustable	
Max. turning angle	15°	
Ambient temperature	+5-40°C	
Ambient humidity	15-90% non condensing	

Label scanner

Optical label scanner
Mechanical label scanner

**The informations in this handbook reflect the state of the publication date.
We reserve the right to make design modifications.**

15.1 Dimensions - systemdesign

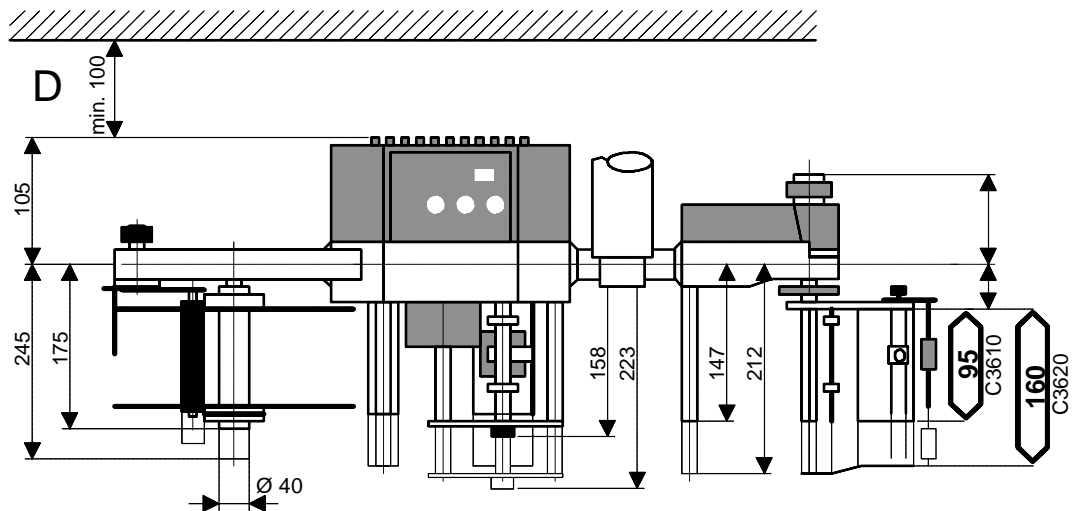
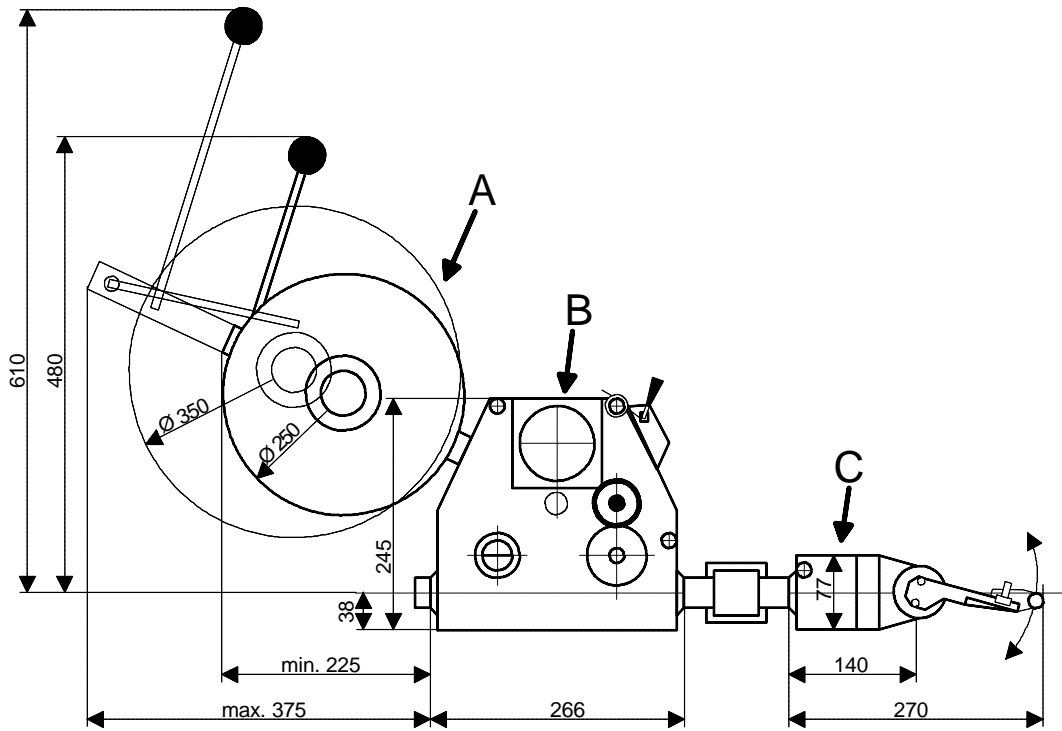

A) Abwickler
B) Vorzugwerk
C) Klappenadapter
D) Für Deckelmontage

A) Unwinder
B) Traction unit
C) Flap adapter
D) For lid dismantling

16 Troubleshooting

16.1 Troubleshooting Collamat 3600

The troubleshooting will proceed along the paperpath. See following figure:

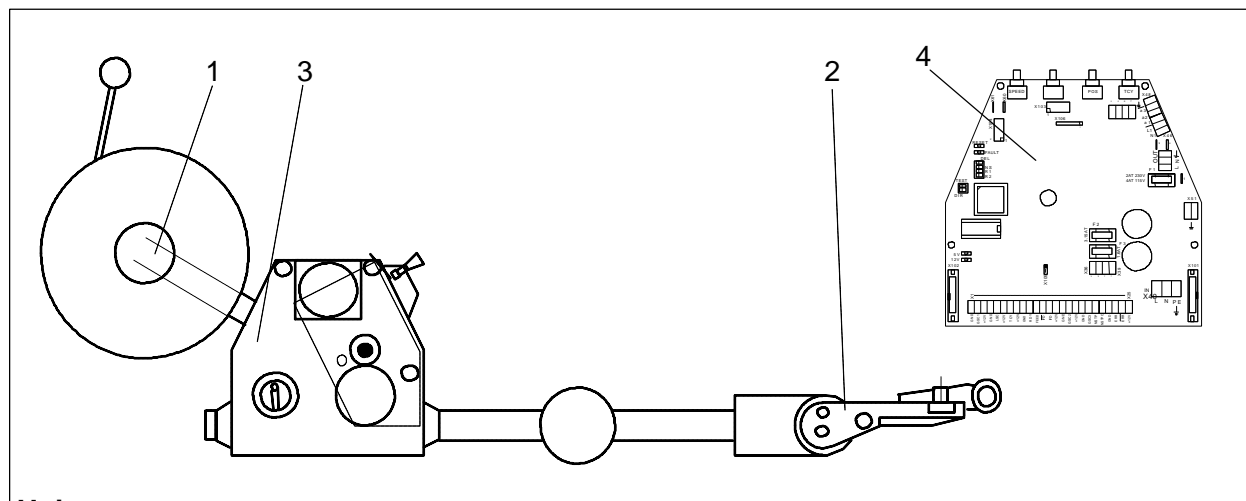

Unit

1. Unwinder 2. Adapter 3. Traction unit 4. Control print

1. Unwinder troubleshooting		
SYMPTOM	DIAGNOSIS	ACTION
Labels peel off at the dancer roll	Dancer roll diameter is too small	Change the standard roll against a roll with enlarged diameter
Dancer arm is bent and breaks	Dancer arm material is too weak or too thin (older Collamat)	Use new dancer arms (C3600/C6600/C8600)
Flange of the fixed disk breaks	Material defect, wrong type of aluminum	Replace flange against new series flange
Unwinder blocks	Disk touches the diskbrake	Shift the disk on the unwindershaft away from the diskbrake
	Shaft is blocked	Lubricate the bearings on the shaft
	Diskbrake does not open	Readjust the diskbrake
The torsion spring comes off the knurled knob	Wrong kind of torsion spring	Exchange the torsion spring against an according torsion spring
The unwinder tends to fall off while side labeling	Paper roll too heavy	Mount a separate clamp to the module rail to stiffen the unwinder rail
Dancer roll gets shaky	Shaft screw is loose	Fix the screw (use perhaps Loctite)
Dancer bearing gets shaky	Module rail is worn out by the dancer axle	Replace module rail and dancer axle
Paperweb falls off in side labeling applications	Missing side labeling kit	Mount the side labeling kit to the Collamat

2. Adapter troubleshooting		
SYMPTOM	DIAGNOSIS	ACTION
Labels run through	Roll-up cable is broken	Replace roll-up cable
	Label sensor cable is broken	Replace label sensor cable
	IR transmitter cable is broken	Replace transmitter cable
	IR transmitter LED broken	Replace transmitter print
	Label sticks below the label sensor	Remove the sensor and clean it properly
	IR light guide is blind	Replace IR light guide
	TCY-potentiometer is misadjusted	Readjust TCY, check DATA-HOLD-switch
	Label scanner position not over the label	Place the scanner over the label transport path
Pressing roll is worn out	Roll is pressed too hard to the goods	Lift the labeler, reduce the adapter spring force
Pressing roll axle hangs/is bent down	Fixing hex nut is loose	Retighten the hex nut (apply Locktite)
	Pressing roll axle is bent or broken	replace the axle
Adapter flap gets shaky	Lever fixing screw is loose	Remove the flange holding the two knurled rolls and retighten the lever
Labels are not dispensed straight forward	Peeling bar is worn out	Replace the peeling bar
Labels form bubbles	Labeling speed too fast	Reduce labeling speed
Labels form wrinkles	Labeling speed too slow	Increase labeling speed
	Labeler is misaligned to product transport	Realign the labeler
Adapter tilts down while labeling	Backing paper not threaded between the adapter roll pair	Tread the paperweb correctly between the adapter roll pair
Paperweb breaks behind the peeling bar	Lateral paperguides hurt the paperweb	Enlarge the space between the paperguides
	Paperbrake set too hard	Reduce the braking force
	Peeling bar is too sharp	Use peeling bar with a bigger radius
		Add Teflon tape around the peeling bar
	Peeling bar touches the goods	Lift the labeler/adapter away from the goods
	Paperweb is perforated	Use unperforated paperwebs or use a peeling bar with bigger radius

3. Traction unit troubleshooting		
SYMPTOM	DIAGNOSIS	ACTION
Pressure roller is shaky	Pressure roller shaft is broken	Replace pressure roller shaft
Traction roller turns in the wrong direction	Problems in the rewinder clutch	Release the breaking force of the rewinder
	Feltdisks are worn out	Replace the felt disks
	Parallel pin inside the rewinder shaft is blocked	Release the parallel pin clean and lubricate it
Potentiometer settings have no effect	DATA-HOLD-switch active	Switch it off
Motor is very hot	No fault	This is normal for a stepper motor
Motor makes high frequent noise	No fault	This is normal for a stepper motor
Traction roller is shaky while power on	Pin at the front flange of the traction roller is broken or worn out	Exchange pin or if necessary exchange the complete traction roller
	The toothed belt roll or the locking plate is broken	Exchange the toothed belt roll or exchange the locking plate and fix it tight
At higher labeling speed the motor stalls	Too much friction of the paperweb	Check the paperbrake
		Add Teflon tape to the peeling bar
		Reduce all friction of the paperweb where possible
At higher labeling speed the motor stalls	Too much friction of the paperweb	Check the unwinder dancer
	Clutching force of the rewinder is too high	Release the breaking force of the rewinder or replace the felt disks
Paperweb breaks behind the paperbrake	Lateral paperguides hurt the paperweb	Enlarge the space between the paperguides
	Paperbrake set too hard	Reduce the braking force

4. Control print troubleshooting		
SYMPTOM	DIAGNOSIS	ACTION
Motor is dead, power switch is not illuminated	No mains connected to trafo	Check for correct main connection
		Check main fuse
		Check internal main switch wiring

4. Control print troubleshooting		
SYMPTOM	DIAGNOSIS	ACTION
Motor is dead, power switch is illuminated, FAULT-LED is on	Motordriver probably not working	Check motordriver fuse F2
		Check for undervoltage
		Check for motordriver overheat
		Check on motorwires for short connection
		Check trafo wiring
Motor turning direction is wrong	Wrong DIL-switch DIR setting	Change DIL-switch DIR
	Wrong Motor wiring	Reconnect motor wires according to the Technical Handbook
Motor makes noise and shakes. It does not turn correctly	Faulty motor driver chip	Replace the board
	Missing connection of one motor wire	Connect motor wires according to the Technical Handbook
No action after power on but motor is under power	Probably set to Nonstop slave mode	Switch Nonstop mode to off
The potentiometers are broken	Transportation damage	Use the original transport box
The primary fuse often blows	The mains impedance is too low	Use an extended power cord
The 5V and 12V LEDs are both off	Fuse F3 is blown, probably result of a short of the 12V in the peripheral units	Check the peripheral units, replace the fuse (1.6AT)
The 12V LED is off	Probably result of a short of the 12V in the peripheral units	Check the peripheral units
The 5V LED is off	Probably result of a short of the 5V in the processor part	Replace the board
The RESET LED is on	Undervoltage of the 5V circuit	Replace the board
The RESET LED periodically flashes	Microprocessor error	Replace the board
	EPROM faulty	Replace the EPROM

16.2 Trouble shooting checklist

Machine-Type:		Ser. No. Dispenser board:	Ser. No. Labeler:
Environment	Mains voltage:	Frequency Hz:	Temperature °C:
	Humidity %:	Interference level (Burst):	Interference level ESD (Static):
Labels	Width:	Length:	Gap:
	Thickness:	Transparency:	Material:
Paperweb	Width:	Thickness:	Transparency:
Goods	Kind:	Material:	Shape:
	Length:	Width:	Height:
	Speed m/min	Length in sense of transport:	Distance between goods:
Labeler	Speed m/min:	Pieces / min:	Measuring:
Settings	Predispensing:	Position mm:	Suppression:
	TCY value:	Label length:	Suppression:
Special:			
Machine-environment	Conveyor:	Feeder:	Taker:
	Other machines around:		
Peripheral units	1	2	3
Screening	Mains cables:	Sensor cables:	
ESD-Phenomena	Description:		
Description of the malfunctions:	Accumulation:		
Date / ev. date and time of the last disturbances:			
Comments:			
Disturbance registered by Name: Date:			

Please make a copy of this list before using it.