

dunkermotoren

D.C. Motors Series GR



D.C. Motors

Series GR

Contents

	D.C. Motors
2	Series GR 22.0
4	Series GR 26.0
6	Series GR 42 x 25 and GR 42 x 40
8	Series GR 53 x 30 and GR 53 x 58
10	Series GR 63 x 25 and GR 63 x 55
12	Series GR 80 x 40 and GR 80 x 80
14	D.C. Gear Motors
15	Motors with Planetary Gears PLG
20	Motors with Spur Gears ZG
24	Motors with Worm Gears SG
29	Motor GR 63 with Gear-Combination SG 80 and PLG 52.0
30	D.C. Motors with Brakes
32	Components for D.C. Motors with Speed Control
33	Analog Value Generators – Tachogenerators TG 11 and TG 52
34	Digital Incremental Encoders RE 30-2, RE 30-3 and RE 56
36	Optical Pulse Generator OI 22
37	Magnetic Pulse Generator MG 2-2
	Accessories
38	Safety Cover and Connector/Connector RE and Circular Connectors
39	Electronic Control Systems
40	1 Quadrant Speed Controller RS 200
42	4 Quadrant Speed Controller RS 400
	Our Delivery Program
	Representatives and Distributors

The details of this data book refer to the specifications of products, but do not represent a guarantee of characteristics. Availability and right to change reserved.

© 2000
Alcatel SEL AG
Components Division
Dunkermotoren
Printed in Germany

D.C.Motors

Series GR 22.0

Due to their extremely small constructional volume and high output, i.e. high output/volume factor, these classically slotted permanent magnet excited small D.C. motors are suitable for such fields of applications as

- Precision engineering
- Photographic, cinematic, optic
- Measuring and control engineering
- Office and data engineering
- Communications engineering
- Servo engineering etc.

Design

The motors are rigidly built and do not require maintenance during their lifetime.

The chromed housing tube acts simultaneously as the return circuit for two segmented magnets which are manufactured from high quality magnetic material. The advantageous slotted-form of the five part rotor plate guarantees high copper/space factor. Five part copper commutator and graphite brushes comprise the commutating system.

The rotor runs in self-lubricating sinter bearings.

The end-shields are manufactured from black, high quality plastic.

It is possible to combine these motors with gears and actual value generators.

Angle dimensions and angle offset

If angles cannot be shown with individual tolerances on scale drawings, the following applies:

The angle dimensions of individual deviate max. $\pm 1^\circ$ from the ideal angle.

The max. angle offset of different graduated circles to each other and from the drive side representation to the non-drive side representation is dependent on the model and can be requested if necessary.

Performance data of motor GR 22.0

	3	6	12	15	24	30	V
Nominal speed ²⁾	3700	4000	5400	5600	4700	4500	min ⁻¹
Nominal torque ²⁾	0,46	0,46	0,47	0,47	0,48	0,48	Ncm
Nominal current ²⁾	$\leq 1,65$	$\leq 0,83$	$\leq 0,47$	$\leq 0,39$	$\leq 0,2$	$\leq 0,16$	A
Rated output power ²⁾	1,78	1,93	2,66	2,76	2,36	2,26	W
No load speed ¹⁾	8000	7800	9100	9400	8100	8100	min ⁻¹
No load current ¹⁾	$\leq 0,35$	$\leq 0,17$	$\leq 0,1$	$\leq 0,09$	$\leq 0,05$	$\leq 0,04$	A
Starting torque ¹⁾	$\geq 1,1$	$\geq 1,09$	$\geq 1,46$	$\geq 1,47$	$\geq 1,42$	$\geq 1,38$	Ncm
Torque constant ¹⁾	0,34	0,72	1,17	1,5	3,0	3,56	Ncm/A
Moment of inertia	2,4	2,4	2,4	2,4	2,4	2,4	gcm ²
Mech. time constant ¹⁾	18,3	18	15,7	16,1	14,3	14,8	ms
Weight	50	50	50	50	50	50	kg

Shaft load capacity axial 4 N max.

Shaft load capacity radial 6 N max. applied 12 mm from mounting surface

All output data are referred to 1) $\partial_R = 20^\circ\text{C}$ resp. 2) $\Delta\partial_w = 100\text{ K}$

Features

- Maximum power with minimum construction volume.
- Stable speed-/torque characteristics.
- High dynamic force due to low mechanical time constant.
- Minimum of pole sensitivity, i.e. lowest possible cogging effect.
- High efficiency.
- Extended mechanical life due to use of long life brushes.
- Low noise levels.
- May be installed in any mounting position, direction of rotation right or left.
- Insulation according to VDE 0530, insulation class E.
- Surface protection.

Standard program

Motors with nominal voltages 6 V, 12 V and 24 V represent our standard motor program and should preferably be used.

Load characteristics

The characteristics are examples for the standard program with the possible winding configurations of the motors, type GR 22.0.



Dimensional drawing · Dimensions in mm

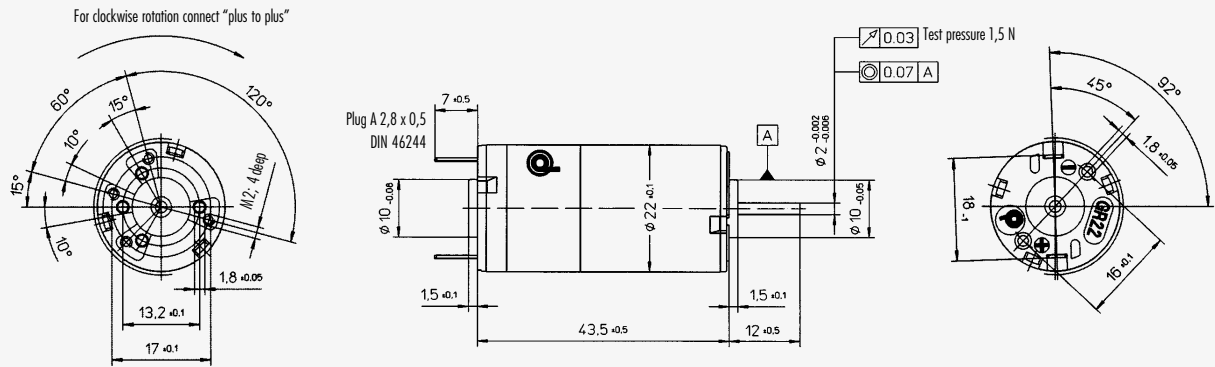

Motor GR 22.0

Please note that differ to the drawing in some cases the rear side shaft may protude up to 2 mm.
The boss diameter is controlled with a cylindrical gauge.

Load characteristics

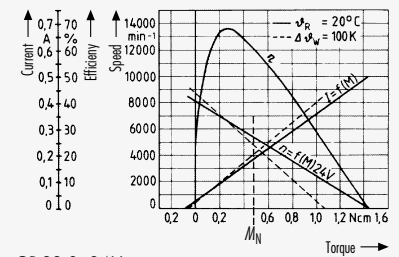
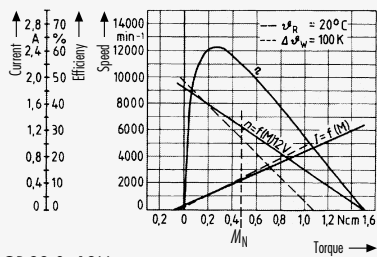
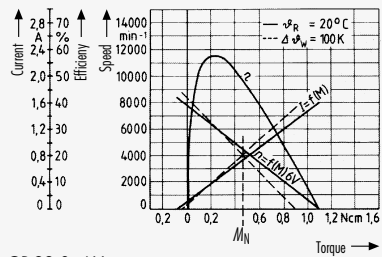

D.C. Motors

Series GR 26.0

The motors in the GR 26.0 series are permanent magnet D.C. motors.

Practically any operating point – nominal voltage, speed and torque – can be realized by a suitable choice of winding.

Due to their small dimensions and high efficiency they are especially suitable for industrial applications such as

- Picture reading equipment
- Document reading apparatus
- Recording equipment
- Welding technics
- Photo, cinema and television.

Design

The motors are rigidly built and do not require maintenance during their lifetime.

The rotor runs in ball bearings.

The bearing plates are of die-cast zinc.

It is possible to combine these motors with gears and actual value encoders resp. generators.

The motors of the GR 26.0 series have a hardened drive shaft.

Features

- Mount-on dimensions according to DIN 42016.
- Independent of mounting position.
- Clockwise and counter-clockwise rotation.
- Insulation according to VDE 0530, insulation class E.
- Surface protection.

Angle dimensions and angle offset

See page 2.

Performance data of motor GR 26.0

Nominal voltage	12	24	V
Nominal speed ²⁾	2600	2500	min ⁻¹
Nominal torque ²⁾	1,25	1,35	Ncm
Nominal current ²⁾	≤0,70	≤0,36	A
No load speed ¹⁾	5000	4800	min ⁻¹
No load current ¹⁾	≤0,12	≤0,065	A
Starting torque ¹⁾	≥3,6	≥3,7	Ncm
Efficiency ²⁾	40	41	%
Moment of inertia	9,8	9,8	gcm ²
Weight	0,14	0,14	kg
Wellenbelastbarkeit axial max.	10 N		
Wellenbelastbarkeit radial max.	22 N applied 12 mm from mounting surface		

All output data are referred to 1) $\vartheta_R = 20^\circ\text{C}$ resp. 2) $\Delta\vartheta_w = 100\text{ K}$

Standard program

Motors with nominal voltages 12 V and 24 V represent our standard motor program and should preferably be used.

Load characteristics

The characteristics are examples for the standard program with the possible winding configurations of the motors, type GR 26.0.



Dimensional drawing · Dimensions in mm

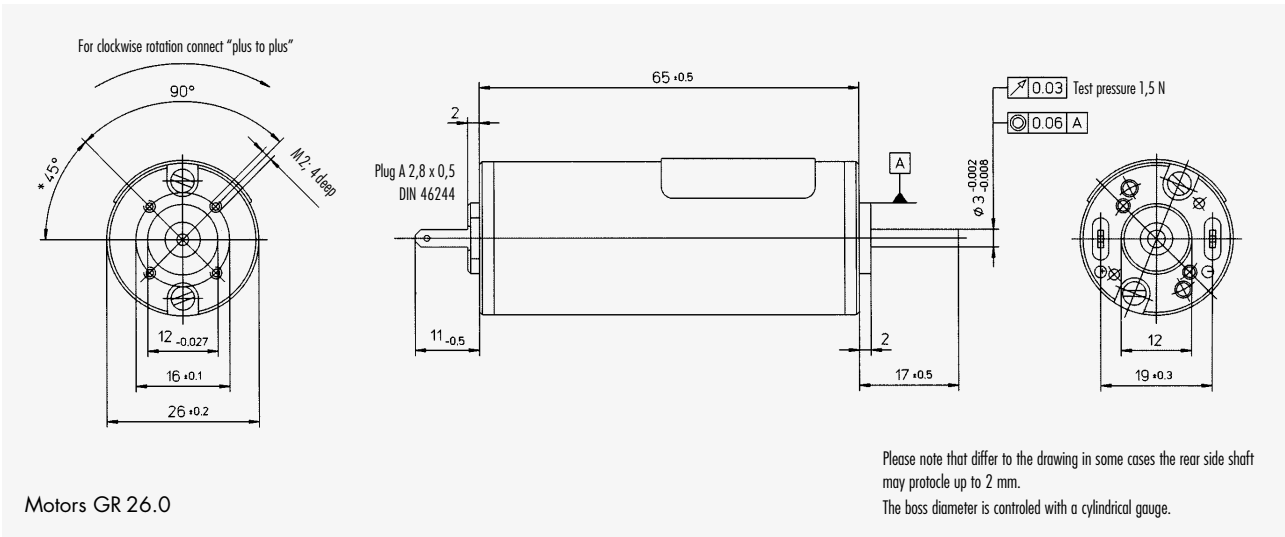

Load characteristics

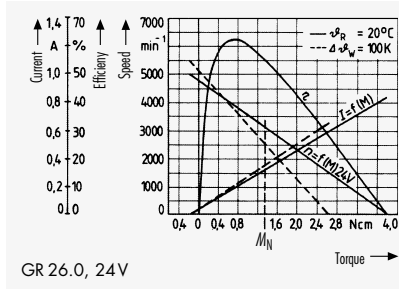
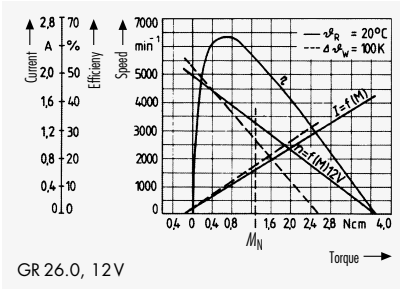

D.C. Motors

Series GR 42x25 and GR 42x40

The motors in the GR 42 series are permanent magnet D.C. motors.

Practically any operating point – nominal voltage, speed and torque – can be realized by a suitable choice of winding.

Due to their small dimensions and high efficiency they are especially suitable for industrial applications such as

- Picture reading equipment
- Document reading apparatus
- Recording equipment
- Welding technics
- Photo, cinema and television.

Design

The motors are rigidly built and do not require maintenance during their lifetime.

A maximum, continuously rated torque of 3,8 to 6 Ncm is obtained with different rotor lengths.

The rotor runs in ball bearings. The bearing plates are of die-cast zinc.

It is possible to combine these motors with gears and actual value encoders resp. generators.

In the place of actual value generators resp. encoders the GR 42 series motors can be equipped with brakes.

Features

- Mount-on dimensions according to DIN 42 016.
- Independent of mounting position.
- Clockwise and counter-clockwise rotation.
- Insulation according to VDE 0530, insulation class E.
- Surface protection.

Angle dimensions and angle offset

See page 2.

Performance data of motor GR 42x25				
Nominal voltage	12	24	40	V
Nominal speed ²⁾	3450	3600	3700	min ⁻¹
Nominal torque ²⁾	3,9	3,8	3,9	Ncm
Nominal current ²⁾	1,85	0,86	0,55	A
Demagnetization current ¹⁾	14	6,5	4,1	A
No load speed ¹⁾	4350	4200	4400	min ⁻¹
No load current ¹⁾	0,34	0,170	0,110	A
Starting torque ¹⁾	18,5	18,5	20,5	Ncm
Efficiency ²⁾	63,5	69	68,6	%
Moment of inertia	71	71	71	gcm ²
Weight	0,39	0,39	0,39	kg

Performance data of motor GR 42x40				
Nominal voltage	12	24	40	V
Nominal speed ²⁾	3750	3100	3400	min ⁻¹
Nominal torque ²⁾	5,3	5,7	5,7	Ncm
Nominal current ²⁾	2,65	1,22	0,8	A
Demagnetization current ¹⁾	24	10,5	6,3	A
No load speed ¹⁾	4550	3800	3950	min ⁻¹
No load current ¹⁾	0,44	0,175	0,12	A
Starting torque ¹⁾	30	31,5	35,6	Ncm
Efficiency ²⁾	65,4	63	63,5	%
Moment of inertia	112	110	110	gcm ²
Weight	0,49	0,49	0,49	kg

Shaft load capacity axial max.	30 N
Shaft load capacity radial max.	60 N applied 20 mm from mounting surface

All output data are referred to 1) $\partial_R = 20^\circ\text{C}$ resp. 2) $\Delta\partial_w = 100\text{ K}$

Standard program

Motors with nominal voltages 12 V and 24 V represent our standard motor program and should preferably be used.

Load characteristics

The characteristics are examples for the standard program with the possible winding configurations of the motors, type GR 42.



Dimensional drawing · Dimensions in mm

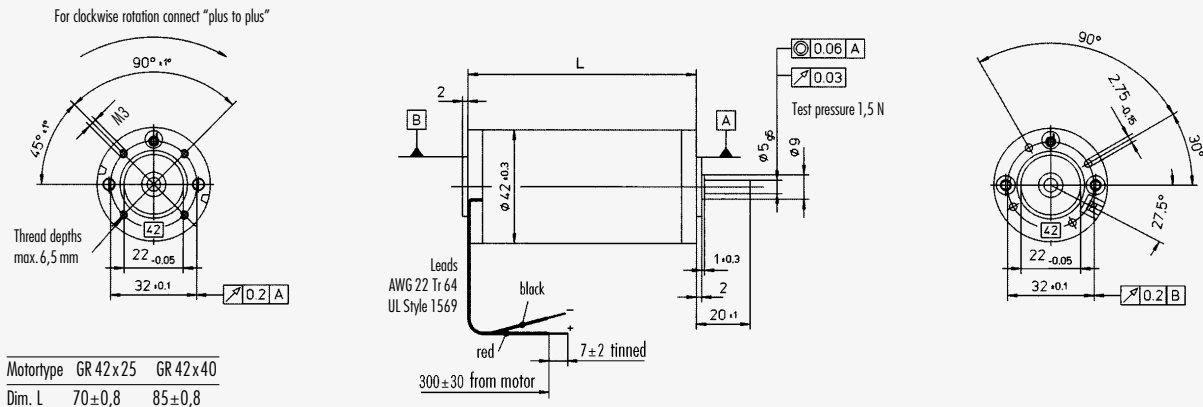

Motors GR 42x25 and GR 42x40

Please note that differ to the drawing in some cases the rear side shaft may protucle up to 2 mm.
The boss diameter is controlled with a cylindrical gauge.

Load characteristics

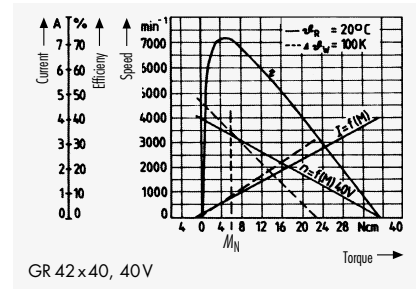
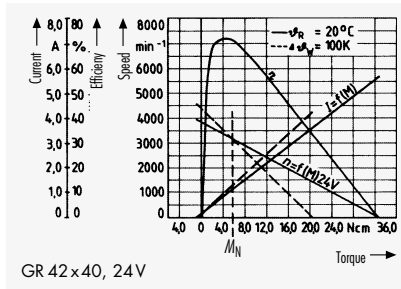
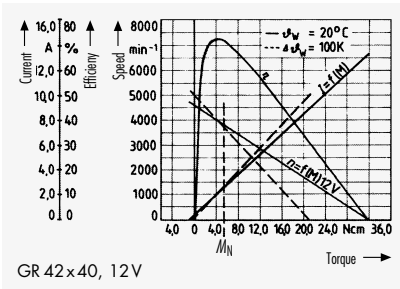
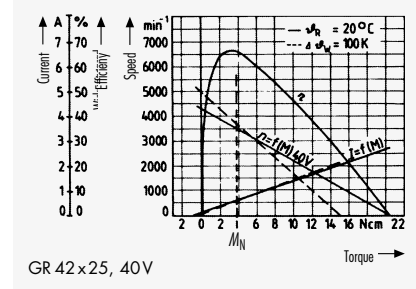
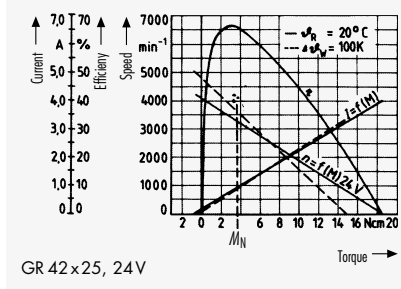
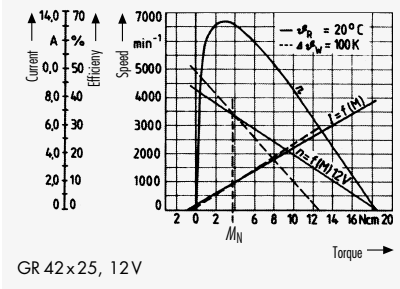

D.C. Motors

Series GR 53x30 and GR 53x58

The motors in the GR 53 series are permanent magnet D.C. motors.

Practically any operating point – nominal voltage, speed and torque – can be realized by a suitable choice of winding.

Due to their small dimensions and high efficiency they are especially suitable for industrial applications such as

- Picture reading equipment
- Document reading apparatus
- Recording equipment
- Welding technics
- Photo, cinema and television.

Design

The motors are rigidly built and do not require maintenance during their lifetime.

Two case-length with continuous torque of 10 resp. 17 Ncm.

The rotor runs in ball bearings. The bearing plates are of die-cast zinc.

It is possible to combine these motors with gears and actual value encoders resp. generators.

The GR 53 series motors can be delivered with brakes and/or actual value encoders resp. generators.

Features

- Mount-on dimensions according to DIN 42016.
- Independent of mounting position.
- Clockwise and counter-clockwise rotation.
- Insulation according to VDE 0530, insulation class E.
- Surface protection.

Standard program

Motors with nominal voltages 12 V and 24 V represent our standard motor program and should preferably be used.

Load characteristics

The characteristics are examples for the standard program with the possible winding configurations of the motors, type GR 53.

Angle dimensions and angle offset

See page 2.

Performance data of motor GR 53x30				
Nominal voltage	12	24	40	V
Nominal speed ²⁾	3790	3600	3680	min ⁻¹
Nominal torque ²⁾	9,0	10	9,6	Ncm
Nominal current ²⁾	≤4,5	≤2,3	≤1,3	A
Demagnetization current ¹⁾	≥42	≥20	≥12	A
No load speed ¹⁾	4490	4200	4280	min ⁻¹
No load current ¹⁾	≤0,580	≤0,280	≤0,170	A
Starting torque ¹⁾	66	67	66	Ncm
Efficiency ²⁾	66	68	68	%
Moment of inertia	233	229	227	gcm ²
Weight	0,85	0,85	0,85	kg

Leistungsdaten Motor GR 53 x 58					
Nominal voltage	12	24	40	60	V
Nominal speed ²⁾	3000	3000	3300	3450	min ⁻¹
Nominal torque ²⁾	15,5	17	17	17	Ncm
Nominal current ²⁾	5,5	2,9	1,9	1,3	A
Demagnetization current ¹⁾	61	31	20	13,5	A
No load speed ¹⁾	3200	3250	3450	3600	min ⁻¹
No load current ¹⁾	0,435	0,200	0,135	0,100	A
Starting torque ¹⁾	110	140	135	140	Ncm
Efficiency ²⁾	73	76	77	78	%
Moment of inertia	460	460	460	460	gcm ²
Weight	1,16	1,16	1,16	1,16	kg
Shaft load capacity axial max.	130N				
Shaft load capacity radial max.	90N applied 20mm from mounting surface				

All output data are referred to 1) $\vartheta_R = 20^\circ\text{C}$ resp. 2) $\Delta\vartheta_w = 100\text{K}$



Dimensional drawing · Dimensions in mm

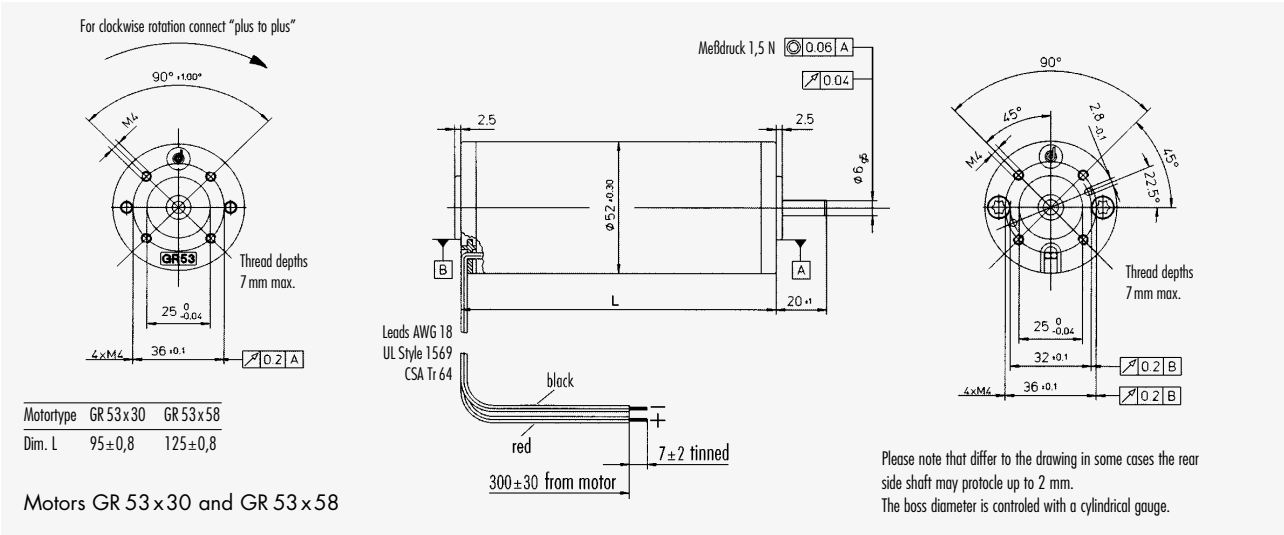

Load characteristics

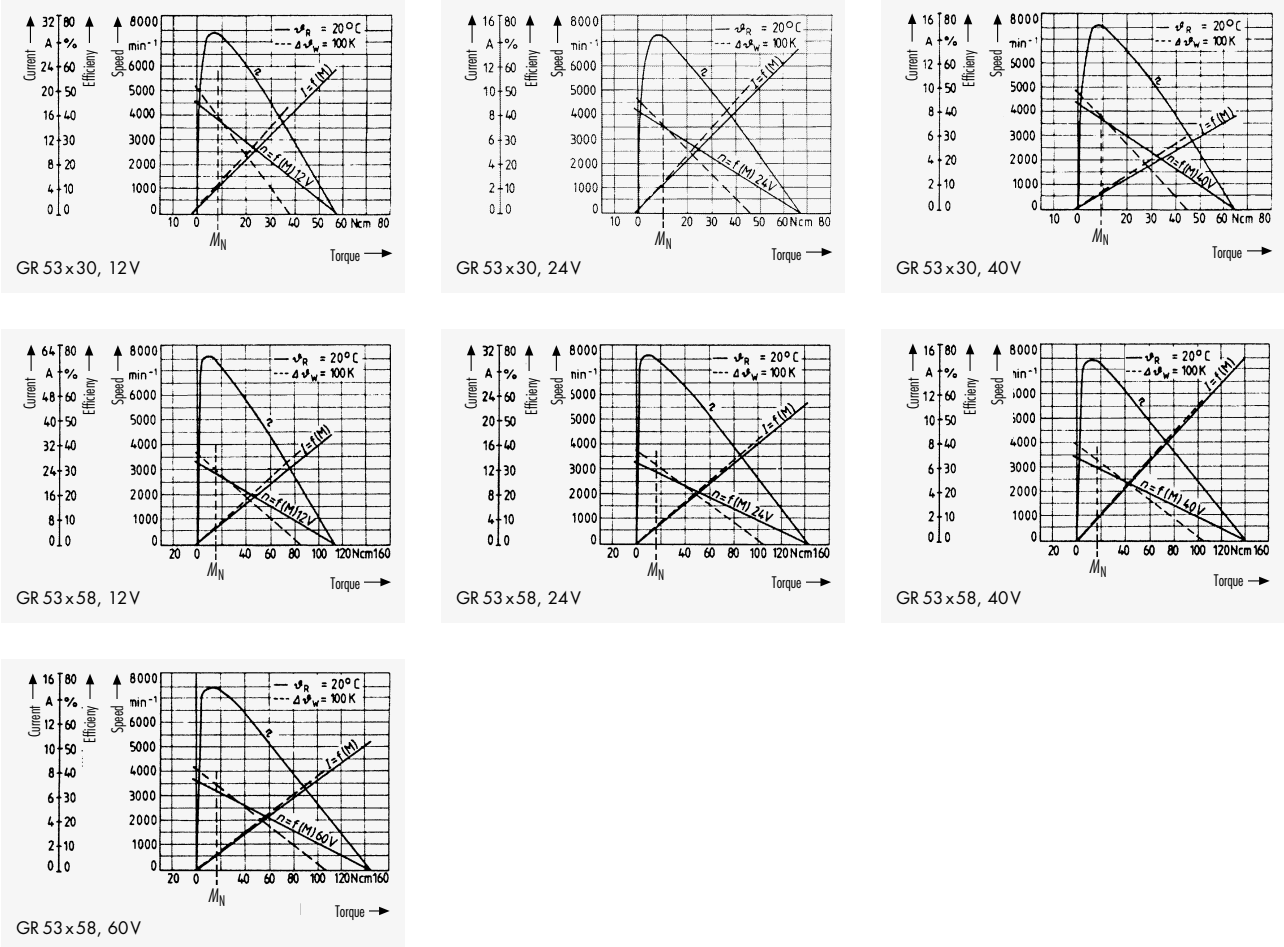

D.C. Motors

Series GR 63x25 and GR 63x55

The type GR 63 motors have permanent magnets and high power at small volume and thus especially suited for industrial applications, such as

- Computer and office machines
- Pumps and compressors
- Industrial blowers
- Welding technics
- General machine construction
- Medical equipment
- Door operating drives

Design

These motors are rigidly built and need no maintenance during their lifetime.

The rotor runs in ball bearings.

The bearing plates are of die cast zinc.

Depending on case-length two versions are available with max. continuous torque of 14 Ncm resp. 28 Ncm.

The motors can be combined with different gears and actual value encoders resp. generators.

The GR 63 series motors can be delivered with brakes and/or actual value encoders resp. generators.

Standard version without second drive shaft and without connector.

Features

- Mount-on dimensions according to DIN 42016.
- Independent of mounting position.
- Clockwise and counter-clockwise rotation.
- Insulation according to VDE 0530, insulation class E.
- Surface protection.

Standard program

Motors with nominal voltages 12 V, 24 V, 40 V and 60 V represent our standard motor program and should preferably be used.

Load characteristics

The characteristics are examples for the standard program with the possible winding configurations of the motors, type GR 63.

Angle dimensions and angle offset

See page 2

Performance data of motor GR 63x25					
Nominal voltage	12	24	40	60	V
Nominal speed ²⁾	3100	3300	3500	3300	min ⁻¹
Nominal torque ²⁾	13,7	14	13,3	14,5	Ncm
Nominal current ²⁾	5,2	2,7	1,65	1,1	A
Demagnetization current ¹⁾	50	24	16	9,5	A
No load speed ¹⁾	3600	3600	3800	3600	min ⁻¹
No load current ¹⁾	0,6	0,36	0,205	0,135	A
Starting torque ¹⁾	82	108	118	116	Ncm
Efficiency ²⁾	71	74	74	76	%
Moment of inertia	400	400	400	400	gcm ²
Weight	1,2	1,2	1,2	1,2	kg

Performance data of motor GR 63x55					
Nominal voltage	12	24	40	60	V
Nominal speed ²⁾	3000	3350	3450	3350	min ⁻¹
Nominal torque ²⁾	24	27	27	28,3	Ncm
Nominal current ²⁾	8,7	4,9	2,95	2,0	A
Demagnetization current ¹⁾	66	33	20	13	A
No load speed ¹⁾	3500	3650	3600	3600	min ⁻¹
No load current ¹⁾	0,8	0,4	0,28	0,2	A
Starting torque ¹⁾	202	211	210	200	Ncm
Efficiency ²⁾	80,5	80	82	82	%
Moment of inertia	750	750	750	750	gcm ²
Weight	1,7	1,7	1,7	1,7	kg

Shaft load capacity axial max.	150 N
Shaft load capacity radial max.	150 N applied 20 mm from mounting surface

All output data are referred to 1) $\vartheta_R = 20^\circ\text{C}$ resp. 2) $\Delta\vartheta_w = 100\text{ K}$



Dimensional drawing · Dimensions in mm

For clockwise rotation connect "plus to plus"

Motor type	GR 63x25
Dim. L	95±0,8
Motor type	GR 63x55
Dim. L	125±0,8

Motors GR 63x25 and GR 63x55

Please note that differ to the drawing in some cases the rear side shaft may protrude up to 2 mm.
The boss diameter is controlled with a cylindrical gauge.

Load characteristics

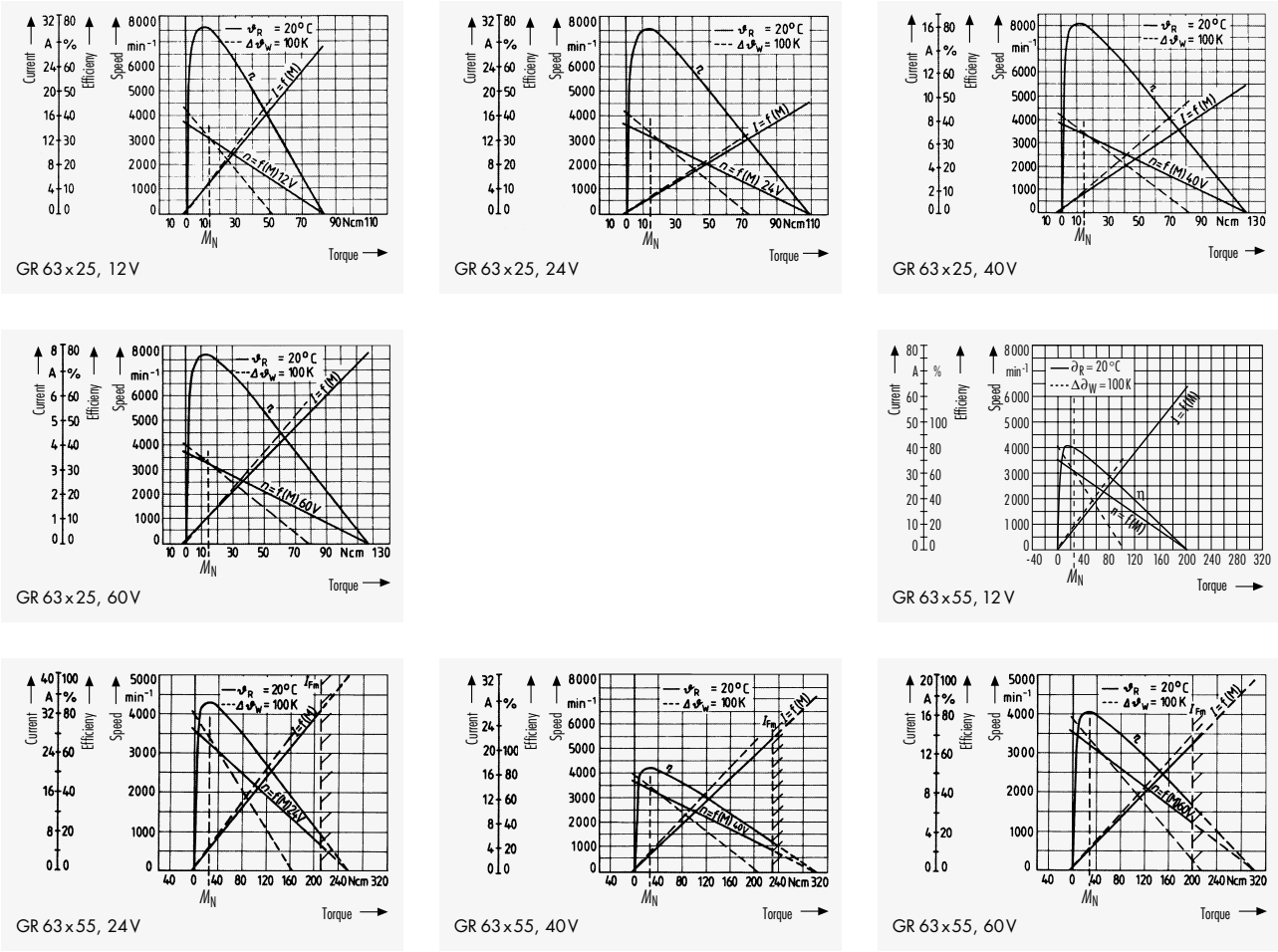

D.C. Motors

Series GR 80x40 and GR 80x80

The type GR 80 motors have permanent magnets and high power at small volume and thus especially suited for industrial applications, such as

- Computer and office machines
- Pumps and compressors
- Industrial blowers
- Welding technics
- General machine construction
- Medical equipment
- Door operating drives

Design

These motors are rigidly built and need no maintenance during their lifetime.

The rotor runs in ball bearings.

The bearing plates are of die cast zinc.

Depending on case-length two versions are available with max. continuous torque of 35 Ncm resp. 63 Ncm.

The motors can be combined with different gears and actual value encoders resp. generators.

The GR 80 series motors can be delivered with brakes and/or actual value encoders resp. generators.

Features

- Mount-on dimensions according to DIN 42016.
- Independent of mounting position.
- Clockwise and counter-clockwise rotation.
- Insulation according to VDE 0530, insulation class E.
- Surface protection.

Standard program

Motors with nominal voltages 24 V, 40 V and 60 V represent our standard motor program and should preferably be used.

Load characteristics

The characteristics are examples for the standard program with the possible winding configurations of the motors, type GR 80.

Angle dimensions and angle offset

See page 2.

Performance data of motor GR 80x40					
Nominal voltage	12	24	40	60	V
Nominal speed ²⁾	2900	2900	3500	3250	min ⁻¹
Nominal torque ²⁾	34,5	34,5	35	35	Ncm
Nominal current ²⁾	11,5	≤5,75	≤4,0	≤2,48	A
Demagnetization current ¹⁾	96	48	32	20	A
No load speed ¹⁾	3200	3200	3450	3400	min ⁻¹
No load current ¹⁾	≤0,962	≤0,463	≤0,325	≤0,240	A
Starting torque ¹⁾	310	320	341	316	Ncm
Efficiency ²⁾	76	76	80	80	%
Moment of inertia	1800	1800	1800	1800	gcm ²
Weight	2,8	2,8	2,8	2,8	kg

Performance data of motor GR 80x80					
Nominal voltage		24	40	60	V
Nominal speed ²⁾		3200	3100	3350	min ⁻¹
Nominal torque ²⁾		62	62	63	Ncm
Nominal current ²⁾		≤10	≤5,95	≤4,2	A
Demagnetization current ¹⁾		91	51	36	A
No load speed ¹⁾		3200	3000	3100	min ⁻¹
No load current ¹⁾		≤0,65	≤0,365	≤0,27	A
Starting torque ¹⁾		608	612	623	Ncm
Efficiency ²⁾		84	85	88	%
Moment of inertia		3200	3200	3200	gcm ²
Weight		4,0	4,0	4,0	kg

Shaft load capacity axial max. 180 N
 Shaft load capacity radial max. 200 N applied 20 mm from mounting surface

All output data are referred to 1) $\vartheta_R = 20^\circ\text{C}$ resp. 2) $\Delta\vartheta_w = 100\text{K}$



Dimensional drawing · Dimensions in mm

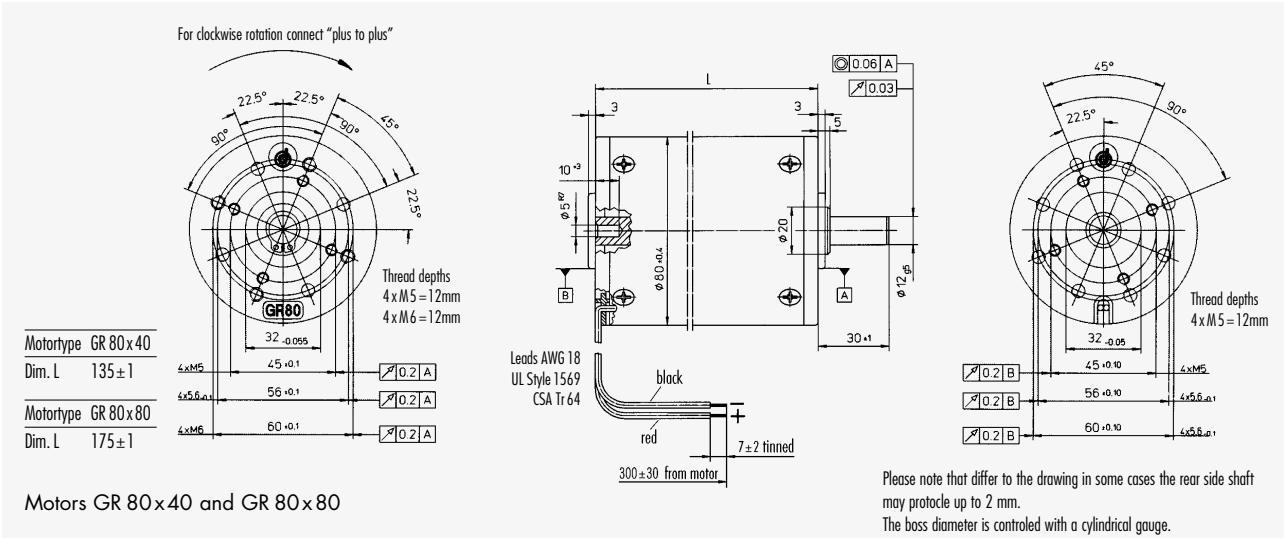

Load characteristics

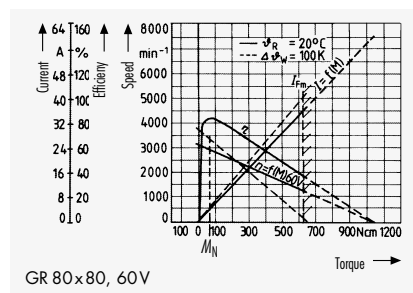
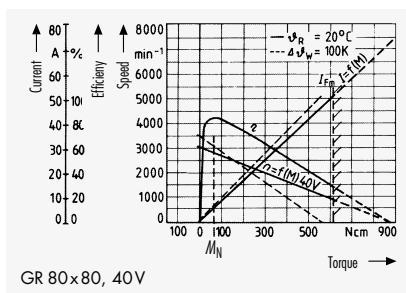
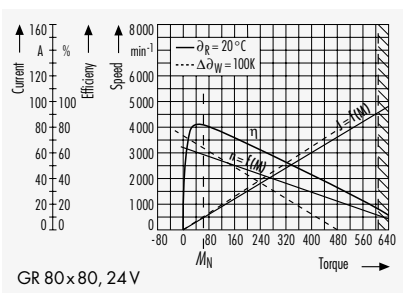
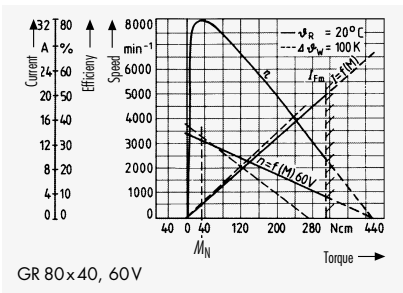
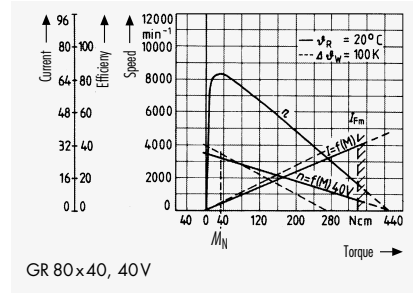
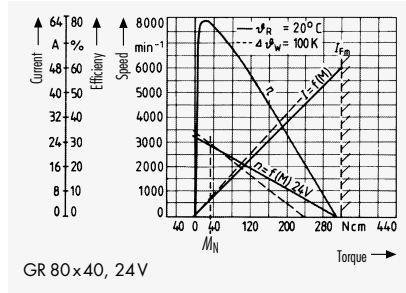
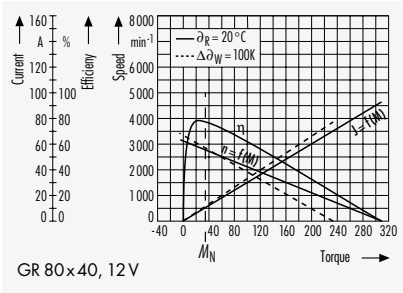

D.C. Gear Motors

Technology of gear design

PLG – Planetary gears

ZG – Spur gears

SG – Worm gears

General recommendations for the choice of a gear motor

Spur gears resp. planetary gears have a higher efficiency than worm gears and are to be preferred whenever possible.

The maximum continuous torque should not be exceeded.

Overload causes gear wear off. In limit cases the next larger gear is preferable.

The motor with the lowest speed should be chosen because this reduces gear wear off and noise.

The operating speed of gears with D.C. motors is mainly depending on the voltage, load and the motor winding.

The advantage of D.C. motors, in comparison to induction motors, is that practically any speed can be realized by a suitable choice of winding (winding turns and wire diameter).

A prediction of the required speed and load ranges can be made from the catalogue.

The correct choice, i.e. the exact matching to your individual requirements can be made on request.

The torque at the gear output shaft is calculated by:

$$M_{\text{gear}} = M_{N \text{ motor}} \cdot i \cdot \eta$$

From the required torque on the gear shaft, the proper motor can be found by using the following formula:

$$M_{\text{Motor}} = \frac{M_{\text{gear}}}{i \cdot \eta}$$

$M_{N \text{ motor}}$ = Nominal motor torque

i = Gear reduction

η = Gear efficiency

M_{gear} = required torque on the gear shaft

Combinations of motors and gears

Motor-type	Planetary gears PLG					Spur gears ZG			Worm gears SG		
	24.0	26.0	32.0	42	52.0* 70	40	80	120	62	80 ¹⁾	120
GR 22.0	●	-	-	-	-	-	-	-	-	-	-
GR 26.0	-	●	●	-	-	●	-	-	-	-	-
GR 42	-	-	-	●	●	-	●	-	●	-	-
GR 53	-	-	-	-	●	-	●	-	●	-	-
GR 63	-	-	-	-	●	●	-	●	-	●	●
GR 80	-	-	-	-	-	●	-	●	-	-	●

Max. load for continuous duty and weight

Gear	Type	Number of stages	Continuous torque max. Ncm	Weight m max. kg
Planetary gears	PLG 24.0	1	30	0,019
		2	45	0,027
		3	60	0,035
	PLG 26.0	1	30	0,081
		2	70	0,107
		3	180	0,13
	PLG 32.0	1	40	0,14
		2	150	0,18
		3	400	0,23
	PLG 42K	1	70	0,16
		2	130	0,2
		3	300	0,25
	PLG 42S	1	350	0,27
		2	600	0,37
		3	1400	0,47
PLG 52.0	1	120	0,55	
	2	800	0,72	
	3	2400	0,88	
PLG 70	1	500	1,7	
	2	4000	2,3	
	3	6000	3,1	
Spur gears	ZG 40	-	bis 50	0,14
	ZG 80	-	bis 600	0,5
	ZG 120	-	bis 2200	2,3
Worm gears	SG 62	-	100 – 150 ²⁾	0,3
	SG 80	-	200 – 400 ²⁾	0,4
	SG 120	-	800 – 1500 ²⁾	2,0

1) It is possible to combine the SG 80 types with the PLG 52.0

2) Depending on the reduction ratio.

D.C. Gear Motors

Motors with Planetary Gears PLG

Planetary gears are especially suitable for industrial applications.

The planetary gears are lubricated with an adhesive grease. These gears make it possible to transmit high torque in a small volume.

Self-centering planetary wheels guarantee a symmetrical distribution of power. The ring gearing also represents the gear casing.

Planetary gear PLG 24.0

Ring gearing and planetary wheels are manufactured from highly durable, temperature resistant plastic.

The output shaft runs in a self-lubricating cylinder bearing of sinter bronze.

Planetary gears PLG 26.0, PLG 32.0, PLG 52.0 and PLG 70

The planetary wheels of the 1st gear stage are made of plastic, the planetary of the 2nd and 3rd stage are made of steel.

The output shaft with its double ball bearings can handle high axial and radial loads.

Planetary gears PLG 42 S

S = Steel

The planetary wheels of the 1st gear stage are made of plastic. Ring gear and planetary wheels of the 2nd and 3rd gear stage are made of steel.

The gear output shaft with its double ball bearings can handle high axial and radial loads.



D.C. Gear Motors

Motors with Planetary Gears PLG

Gear unit types

Planetary gears PLG 24.0

for continuous torques
1 stage up to 30 Ncm
2 stages up to 45 Ncm
3 stages up to 60 Ncm

Shaft load capacity axial 5 N max.
Shaft load capacity radial 12 N max.
applied in center of gear shaft

Ratio :1	Efficiency	Stages
4,33	0,91	1
6	0,91	1
18,75	0,83	2
33,2	0,83	2
46	0,83	2
81,2	0,76	3
143,8	0,76	3
199,3	0,76	3
276	0,76	3
353	0,76	3

Planetary gears PLG 42 S (Steel)

for continuous torques
1 stage up to 350 Ncm
2 stages up to 600 Ncm
3 stages up to 1400 Ncm

Shaft load capacity axial 150 N max.
Shaft load capacity radial 250 N max.
applied 20 mm from mounting surface

Ratio :1	Efficiency	Stages
4	0,8	1
6,25	0,8	1
8	0,8	1
16	0,75	2
25	0,75	2
32	0,75	2
50	0,75	2
64	0,75	2
100	0,7	3
128	0,7	3
156	0,7	3
200	0,7	3
256	0,7	3
312,5	0,7	3
400	0,7	3
512	0,7	3

Planetary gears PLG 26.0

for continuous torques
1 stage up to 30 Ncm
2 stages up to 70 Ncm
3 stages up to 180 Ncm

Shaft load capacity axial 20 N max.
Shaft load capacity radial 40 N max.
applied in center of gear shaft

Ratio :1	Efficiency	Stages
4,33	0,85	1
6	0,85	1
18,75	0,72	2
33,2	0,72	2
46	0,72	2
81,2	0,61	3
143,8	0,61	3
199,3	0,61	3
276	0,61	3
353	0,61	3

Planetary gears PLG 52.0

for continuous torques
1 stage up to 120 Ncm
2 stages up to 800 Ncm
3 stages up to 2400 Ncm

Shaft load capacity axial 500 N max.
Shaft load capacity radial 350 N max.
applied in center of Woodruff key

Ratio :1	Efficiency	Stages
4,5	0,85	1
6,25	0,85	1
8	0,85	1
20,25	0,72	2
28,12	0,72	2
36	0,72	2
50	0,72	2
64	0,72	2
91,12	0,61	3
126,56	0,61	3
162	0,61	3
225	0,61	3
288	0,61	3
400	0,61	3
512	0,61	3

Planetary gears PLG 32.0

for continuous torques
1 stage up to 40 Ncm
2 stages up to 150 Ncm
3 stages up to 400 Ncm

Shaft load capacity axial 30 N max.
Shaft load capacity radial 100 N max.
applied in center of gear shaft

Ratio :1	Efficiency	Stages
4,5	0,85	1
6,25	0,85	1
20,25	0,72	2
36	0,72	2
50	0,72	2
91,12	0,61	3
162	0,61	3
288	0,61	3
400	0,61	3

Planetary gears PLG 70

for continuous torques
1 stage up to 500 Ncm at shorttime 10 Nm
2 stages up to 4000 Ncm at shorttime 60 Nm
3 stages up to 6000 Ncm at shorttime 100 Nm

Shaft load capacity axial 1000 N max.
Shaft load capacity radial 650 N max.
applied 25 mm from mounting surface

Ratio :1	Efficiency	Stages
4	0,8	1
5,8	0,8	1
7	0,8	1
16	0,75	2
23,2	0,75	2
28	0,75	2
33,64	0,75	2
40,6	0,75	2
49	0,75	2
64	0,7	3
92,8	0,7	3
112	0,7	3
134,56	0,7	3
162,4	0,7	3
195,112	0,7	3
235,48	0,7	3
284,2	0,7	3
343	0,7	3

Dimensional drawings · Dimensions in mm

Motor	Gear	Dim. A	Dim. B
GR 22.0	1 stage	62,8	19,3
	2 stages	70,5	27,0
	3 stages	78,2	34,7

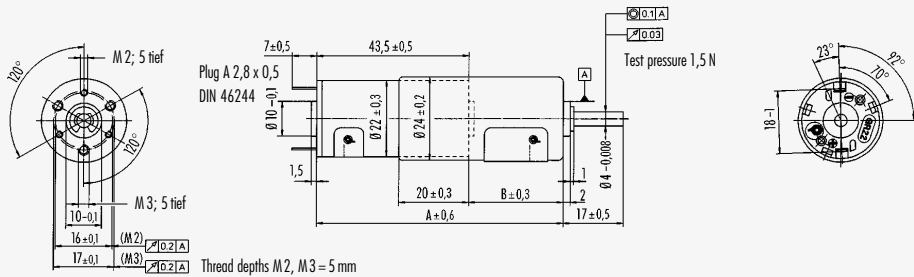

Motor GR 22.0 with gear PLG 24.0 – plug connection

Motor	Gear	Dim. <i>l</i> ₁	Dim. <i>l</i> ₂
GR 26.0	1 stage	95	30
	2 stages	104	39
	3 stages	113	48

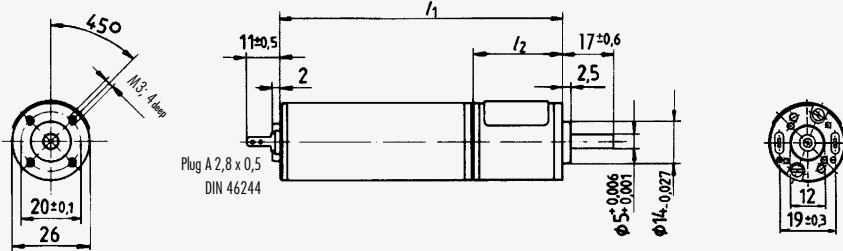

Motor GR 26.0 with gear PLG 26.0 – plug connection

Motor	Gear	Dim. <i>l</i> ₁	Dim. <i>l</i> ₂
GR 26.0	1 stage	95	29
	2 stages	105	39
	3 stages	115	49

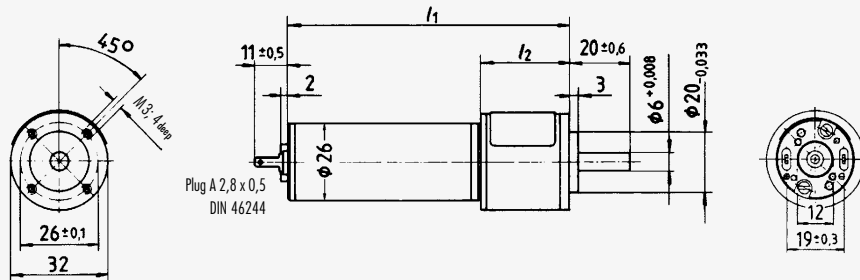

Motor GR 26.0 with gear PLG 32.0 – plug connection

Motor	Gear	Dim. <i>l</i> ₁	Dim. <i>l</i> ₂
GR 42x25	1 stage	100±1,6	30
	2 stages	110±1,6	40
	3 stages	120±1,6	50
GR 42x40	1 stage	115±1,6	30
	2 stages	125±1,6	40
	3 stages	135±1,6	50

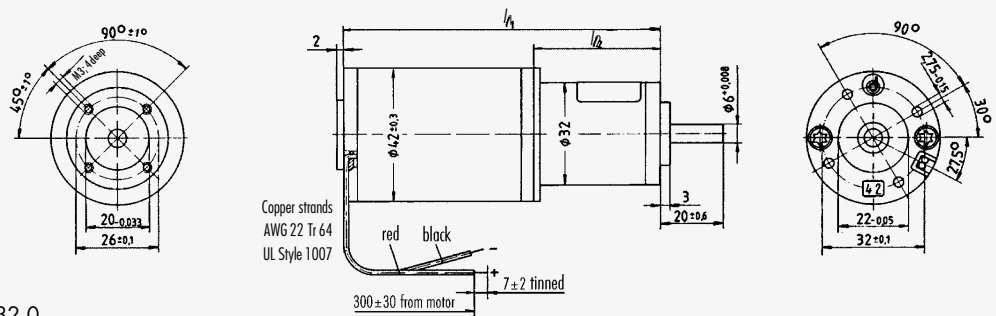

Motor GR 42 with gear PLG 32.0

D.C. Gear Motors

Motors with Planetary Gears PLG

Dimensional drawings · Dimensions in mm

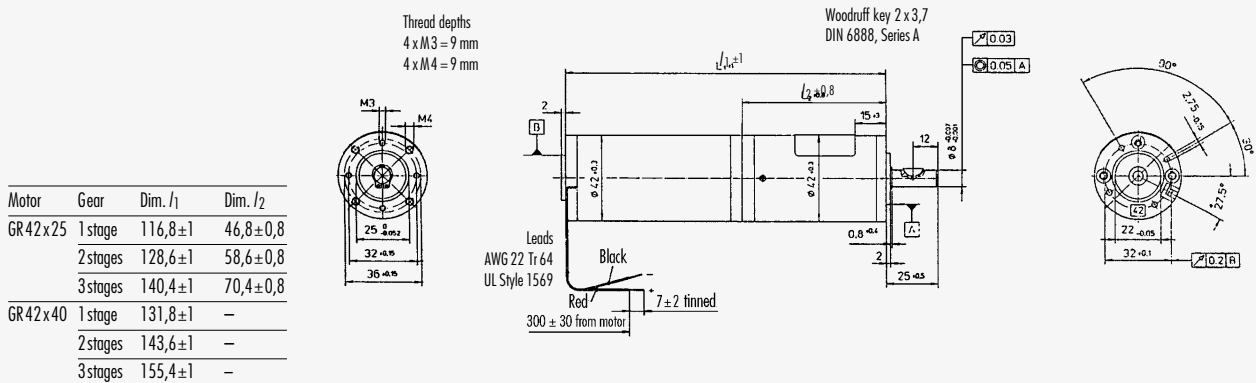

Motor GR 42 with gear PLG 42 S

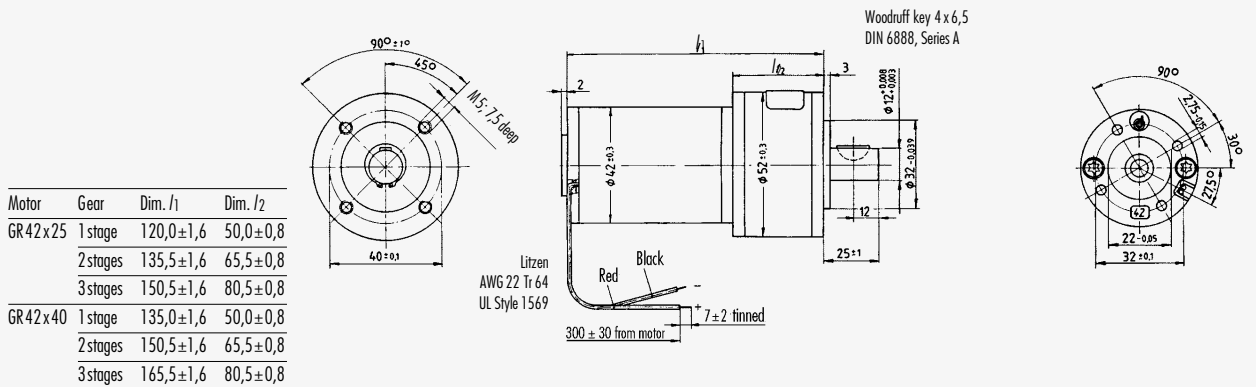

Motor GR 42 with gear PLG 52.0

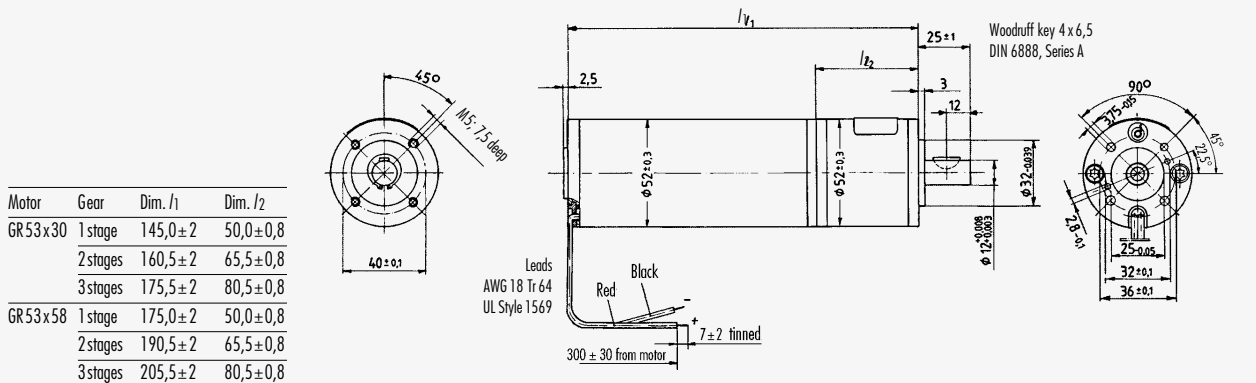

Motor GR 53 with gear PLG 52.0

Dimensional drawings · Dimensions in mm

Motor	Gear	Dim. l_1	Dim. l_2
GR 63x25	1 stage	145,0±2	50,0±0,8
	2 stages	160,5±2	65,5±0,8
	3 stages	175,5±2	80,5±0,8
GR 63x55	1 stage	175,0±2	50,0±0,8
	2 stages	190,5±2	65,5±0,8
	3 stages	205,5±2	80,5±0,8

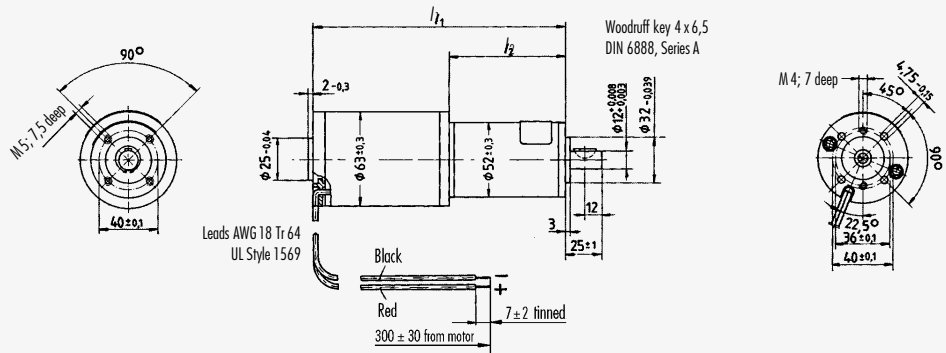

Motor GR 63 with gear PLG 52.0

Motor	Gear	Dim. l_1	Dim. l_2
GR 63x25	1 stage	177,0±1,6	82±0,8
	2 stages	209,0±1,6	114±0,8
	3 stages	241,0±1,6	146±0,8
GR 63x55	1 stage	207,0±1,6	82±0,8
	2 stages	239,0±1,6	114±0,8
	3 stages	271,0±1,6	146±0,8

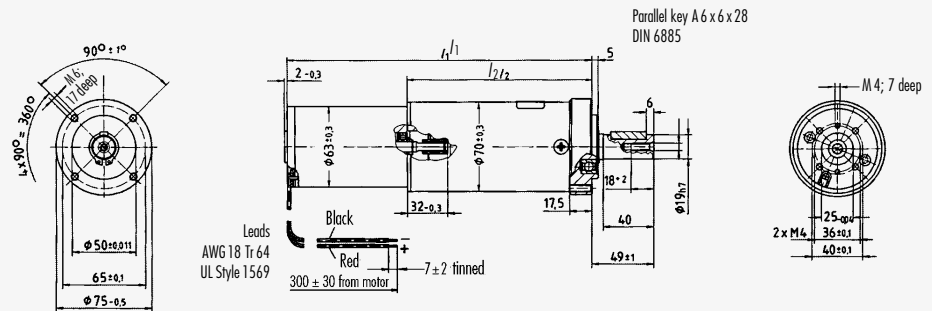

Motor GR 63 with gear PLG 70

Motor	Gear	Dim. l_1	Dim. l_2
GR 80x40	1 stage	217,0±1,8	82±0,8
	2 stages	249,0±1,8	114±0,8
	3 stages	281,0±1,8	146±0,8
GR 80x80	1 stage	257,0±1,8	82±0,8
	2 stages	289,0±1,8	114±0,8
	3 stages	321,0±1,8	146±0,8

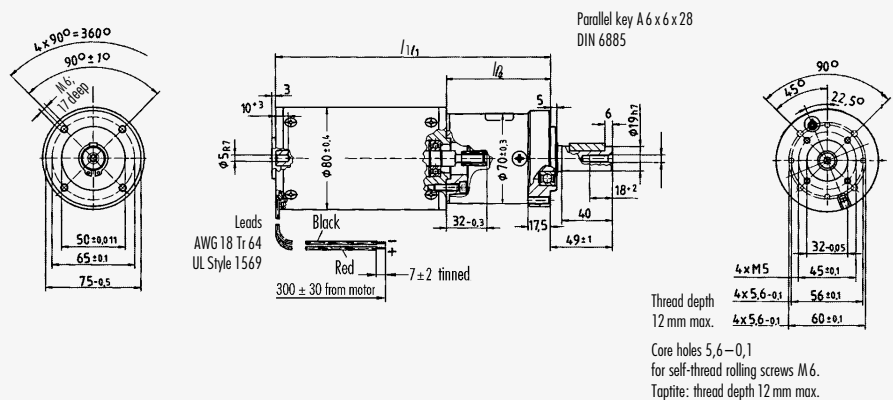

Motor GR 80 with gear PLG 70

D.C. Gear Motors

Motors with Spur Gears ZG

Spur gears have a compact design and a high efficiency. The adhesive lubrication guarantees a high lifetime at the nominal torques stated.

Spur gear ZG 40

The die-cast housing is foreseen for foot mounting. The gearing parts are made of steel.

The gear output shaft runs in a self-lubricating sintered bearing bush.

Spur gear ZG 80

The zinc die-cast housing is designed for flange mounting.

The gearing is made of steel and the first stage is made of laminated plastic.

Partial using of helical wheels gives the gears quiet running and a high service life.

The gear output shaft runs in a self-lubricating sintered bearing bush.

Spur gear ZG 120

The foot mounting design B3 shows also version type B14 for flange mounting providing the gears for universal applications.

High-grade gearing, hardened and ground, guarantees a high lifetime at the nominal torques stated.

The using of helical wheels in the first stage gives quiet running and a high service life.

The standard output shaft of the gear runs in a ball bearing and can handle high radial and axial loads.

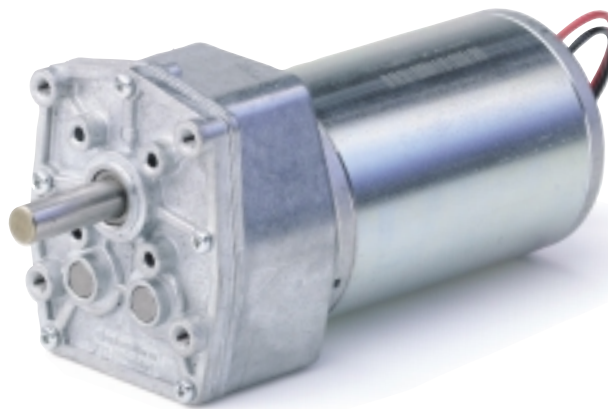

Gear unit types

Spur gears ZG 40

for continuous torques
up to 50 Ncm

Shaft load capacity axial	20 N max.
Shaft load capacity radial applied 20 mm from mounting surface	20 N max.

Ratio : 1	Efficiency	Stages
5	0,81	2
10	0,81	2
20	0,73	3
30	0,73	3
40	0,73	3
75	0,65	4
100	0,65	4
200	0,59	5
250	0,59	5
400	0,59	5
750	0,53	6
1000	0,53	6

Spur gears ZG 80

for continuous torques
2 stages up to 250 Ncm
3 stages up to 500 Ncm
4 stages up to 600 Ncm

Shaft load capacity axial	80 N max.
Shaft load capacity radial applied in center of Woodruff key	80 N max.

Ratio : 1	Efficiency	Stages
5,6	0,81	2
8,7	0,81	2
11,3	0,81	2
15,6	0,81	2
23,9	0,73	3
37,3	0,73	3
48,7	0,73	3
66,9	0,73	3
112,8	0,65	4
147,1	0,65	4
202,1	0,65	4

Spur gears ZG 120

for continuous torques
1 stage up to 400 Ncm
2 stages up to 1000 Ncm
3 stages up to 2200 Ncm

Shaft load capacity axial	600 N max.
Shaft load capacity radial applied in center point of parallel key	600 N max.

Ratio : 1	Efficiency	Stages
3	0,90	1
5,1	0,90	1
8	0,81	2
13,7	0,81	2
21,6	0,72	3
37,1	0,72	3
58,6	0,66	4
100,4	0,66	4
158,5	0,60	5
271,6	0,60	5
428,9	0,55	6
735	0,55	6

D.C. Gear Motors

Motors with Spur Gears ZG

Dimensional drawings · Dimensions in mm

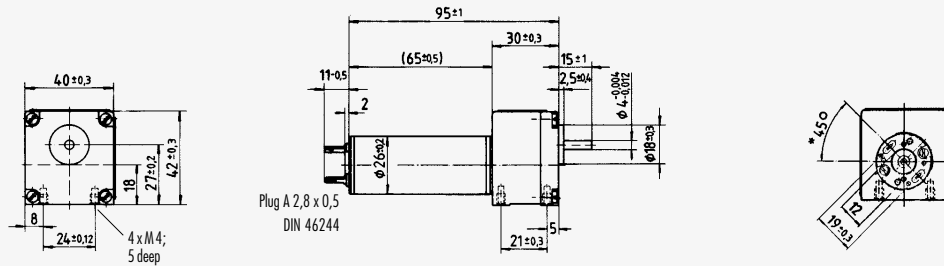

Motor GR 26.0 with gear ZG 40

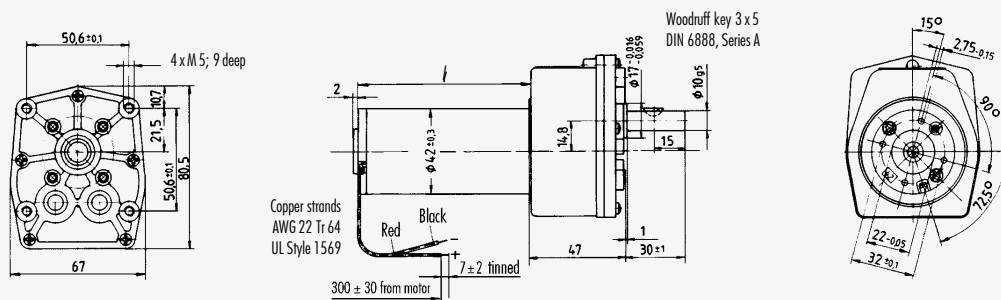

Motor	Dim. /
GR 42x25	70±0,8
GR 42x40	85±0,8

Motor GR 42 with gear ZG 80

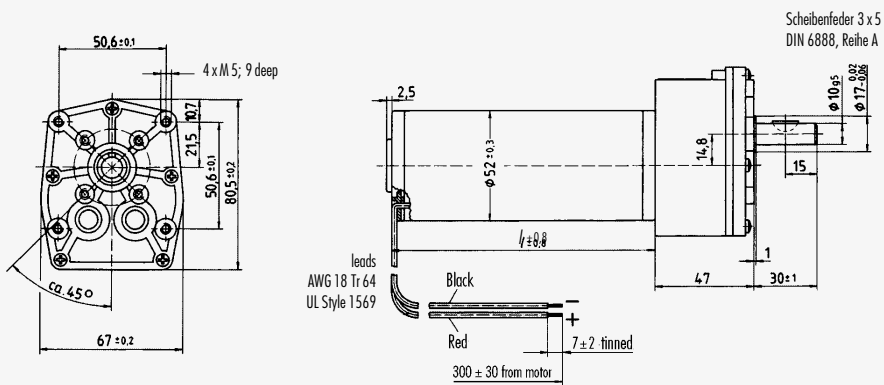

Motor	Dim. /
GR 53x30	95±0,8
GR 53x58	125±0,8

Motor GR 53 with gear ZG 80

Dimensional drawings · Dimensions in mm

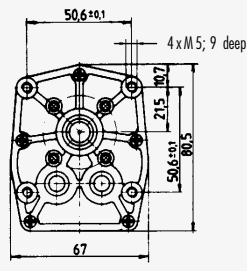

50.6±0.1
4 x M5; 9 deep
21.5
10.7
50.6±0.1
80.5
67

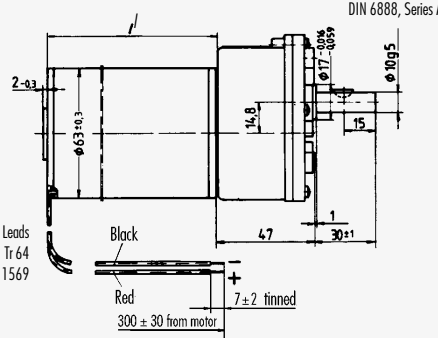

Woodruff key 3 x 5
DIN 6888, Series A
2-0.3
φ63±0.3
14.8
φ17-0.009
φ10g5
15
47
1
30±1
Leads
AWG 18 Tr 64
UL Style 1569
Black
Red
7±2 tinned
300 ± 30 from motor

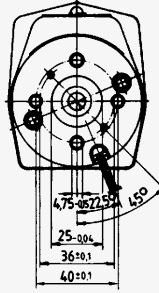

4.75±0.25
1.50
25-0.06
36±0.1
40±0.1

Motor	Dim. /
GR 63 x 25	95 ± 0,8
GR 63 x 55	125 ± 0,8

Motor GR 63 with gear ZG 80

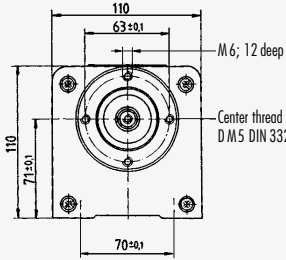

110
63±0.1
M6; 12 deep
Center thread
D M 5 DIN 332
71±0.1
70±0.1

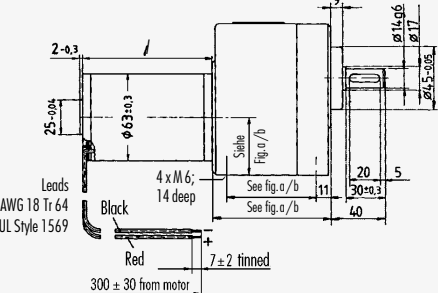

Parallel key A5 x 5 x 20
DIN 6888
2-0.3
25-0.04
φ63±0.3
9
9
φ14g6
φ17
φ15-0.05
11
20
5
30±0.3
40
Leads
AWG 18 Tr 64
UL Style 1569
Black
Red
7±2 tinned
300 ± 30 from motor
4 x M 6;
14 deep
Siehe Fig. a/b
Siehe Fig. a/b

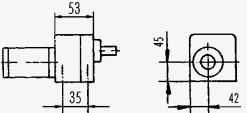

Fig.a: One- and two-stage design

Motor	Dim. /
GR 63 x 25	95 ± 0,8
GR 63 x 55	125 ± 0,8

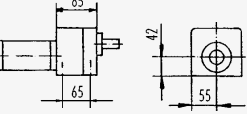
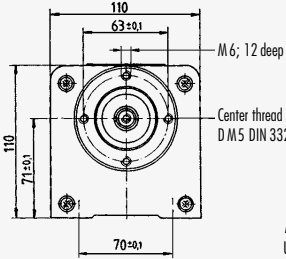
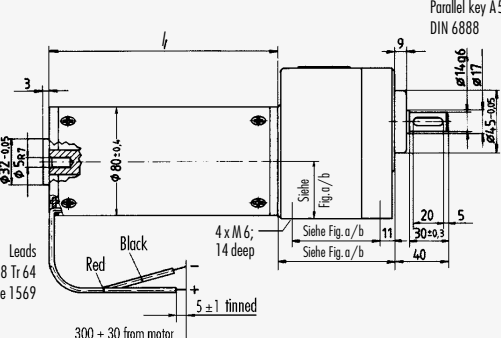

Fig.b: Three- to six-stage design

Motor GR 63 with gear ZG 120



110
63±0.1
M6; 12 deep
Center thread
D M 5 DIN 332
71±0.1
70±0.1



Parallel key A5 x 5 x 20
DIN 6888
3
φ32-0.05
φ5h7
φ80±0.1
9
9
φ14g6
φ17
φ15-0.05
11
20
5
30±0.3
40
Leads
AWG 18 Tr 64
UL Style 1569
Black
Red
5±1 tinned
300 ± 30 from motor
4 x M 6;
14 deep
Siehe Fig. a/b
Siehe Fig. a/b

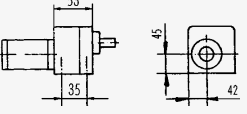

Fig.a: One- and two-stage design

Motor	Dim. /
GR 80 x 40	135 ± 1
GR 80 x 80	175 ± 1

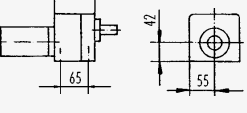

Fig.b: Three- to six-stage design

Motor GR 80 with gear ZG 120

D.C. Gear Motors

Motors with Worm Gears SG

A special feature of the worm gears is the smooth running.

The zinc die-cast is designed for foot and flange mounting. The worm shaft has bearings on both sides.

The gearing is made out of steel and bronze parts. The lubricating crease guarantees a high lifetime at the rated torques stated.

Worm gears, series SG 62

At the standard type gear the output shaft runs in a self-lubricating sintered bearing bush and is brought out one-sided on the left.

Ball bearings are possible as special design.

Worm gears, series SG 80

At the standard type gear the output shaft runs in a self-lubricating sintered bearing bush and is brought out one-sided on the left.

Ball bearings are possible as special design.

Worm gears, series SG 120

At the standard gear the output shaft runs in ball bearings and is brought out one-sided on the left.

Position of gear output shaft at worm gears

The standard gear output shaft for series production is, in top view, unidirectionally left (WL1). Special versions are possible.



WL1 Standard version
Shaft left



WL2 Special version
Shaft right



WL3 Special version
Shaft on both sides

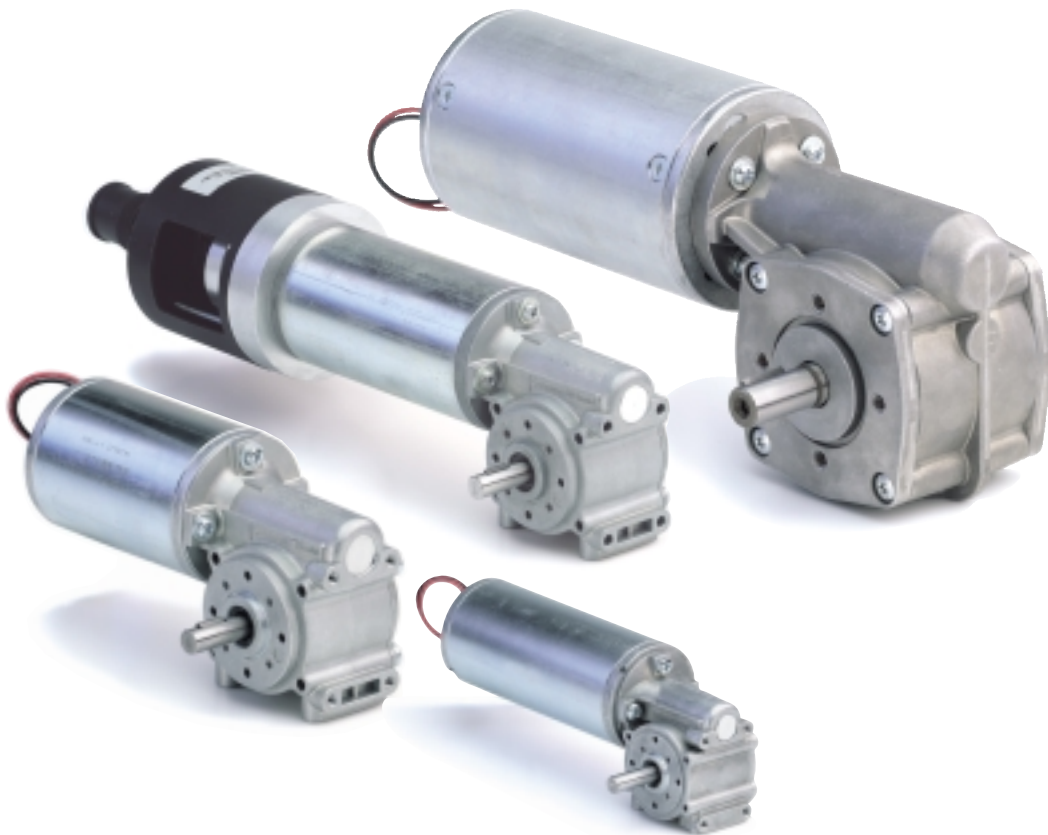

Gear unit types

Worm gears SG 62

for continuous torques
up to 150 Ncm, at shorttime up to 300 Ncm

Shaft load capacity axial	40 N max.
Shaft load capacity radial applied in center of standard gear shaft	40 N max.

Ratio : 1	Efficiency	Continuous torques max. Ncm
8	0,60	100
15	0,55	100
23	0,50	150
35	0,45	150
46	0,40	150
72	0,30	150

Combination
worm gear SG 62 and
planetary gear PLG 52.0
on request.

Worm gears SG 80

for continuous torques
up to 400 Ncm, at shorttime up to 800 Ncm

Shaft load capacity axial	50 N max.
Shaft load capacity radial applied in center point of Woodruff key	60 N max.

Ratio : 1	Efficiency	Continuous torques max. Ncm
5	0,70	200
10	0,65	250
15	0,55	300
24	0,50	350
38	0,40	350
50	0,35	400
75	0,25	400

Worm gears SG 120

for continuous torques
up to 1500 Ncm

Shaft load capacity axial	300 N max.
Shaft load capacity radial bei Mitte Paßfeder	500 N max.

Ratio : 1	Efficiency	Continuous torques max. Ncm
8	0,70	800
10	0,70	1000
15	0,65	1000
20	0,55	1500
30	0,50	1500
40	0,40	1500
50	0,35	1500
60	0,30	1500
70	0,28	1500
80	0,25	1500

Combination
worm gear SG 120 and
planetary gear PLG 70
on request.

**Worm gear SG 80 with
Planetary gear PLG 52.0**

PLG for continuous torques
1 stage up to 70 Ncm
2 stages up to 130 Ncm
3 stages up to 2400 Ncm

PLG-Shaft load capacity axial 500 N max.
PLG-Shaft load capacity radial 350 N max.
applied in center point of parallel key

Total Ratio	SG 80 Ratio :1	PLG 52.0 Ratio :1
22	5	4,5
31	5	6,25
45	10	4,5
62	10	6,25
101	5	20,25
180	5	36
250	5	50
360	10	36
500	10	50
750	15	50
1 200	24	50
1 900	38	50
2 500	50	50
4 000	10	400
6 000	15	400
9 600	24	400
15 200	38	400
20 000	50	400
30 000	75	400

Further ratio combinations
on request.

Combination
worm gear SG 80 and
planetary gear PLG 52.0
see page 29.

D.C. Gear Motors

Motors with Worm Gears SG

Dimensional drawings · Dimensions in mm

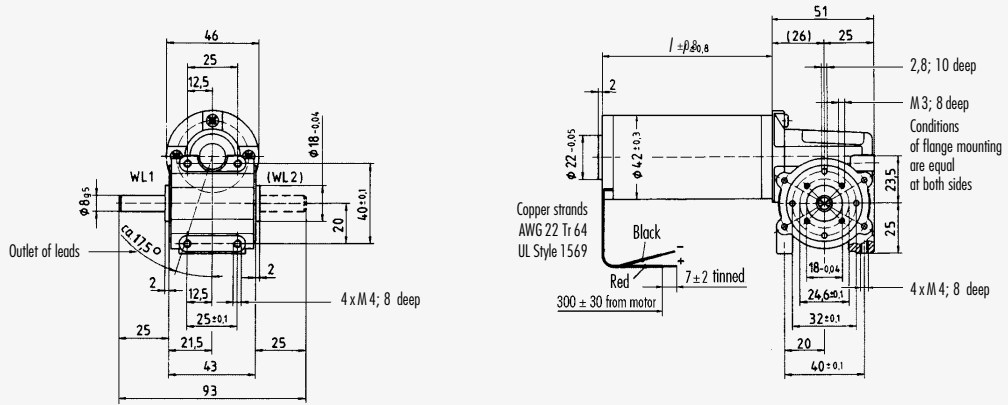

Motor GR 42 with gear SG 62

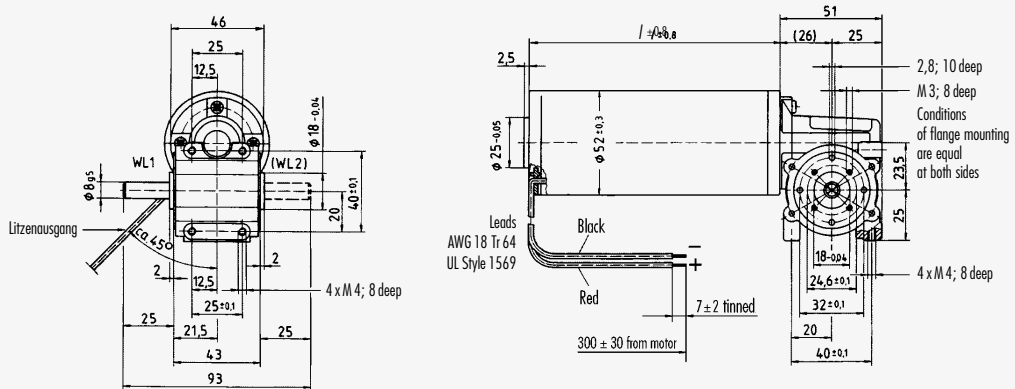

Motor GR 53 with gear SG 62

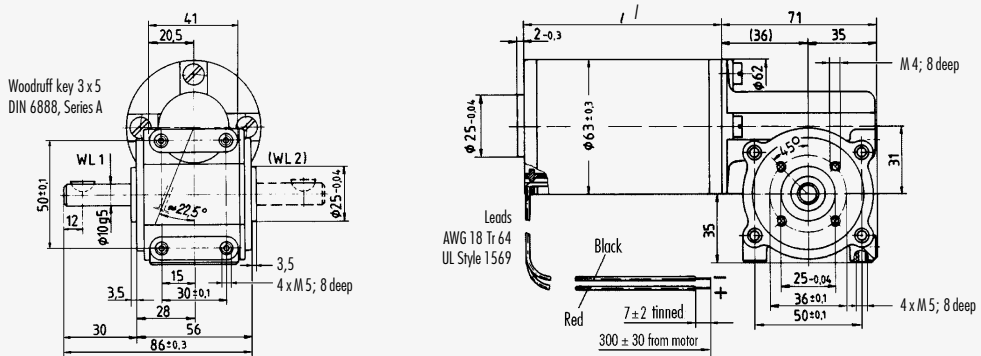

Motor GR 63 with gear SG 80

Dimensional drawings · Dimensions in mm

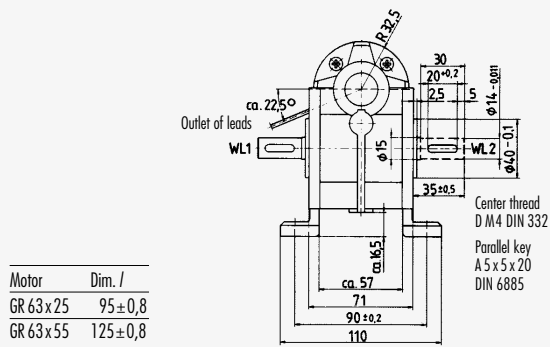

Motor GR 63 with gear SG 120
in foot version B3

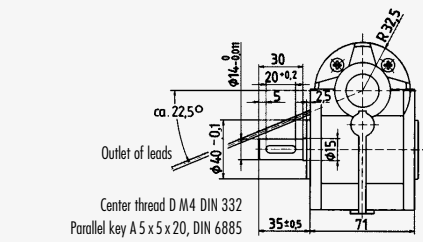
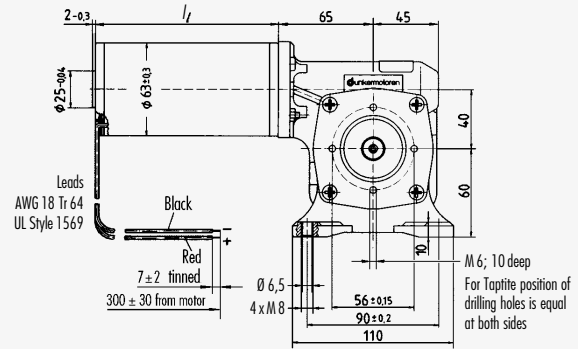

Motor GR 63 with gear SGF 120-B14
in flange version B14

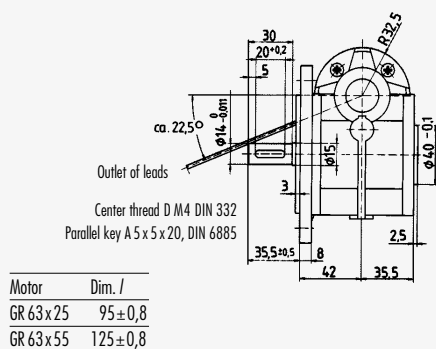
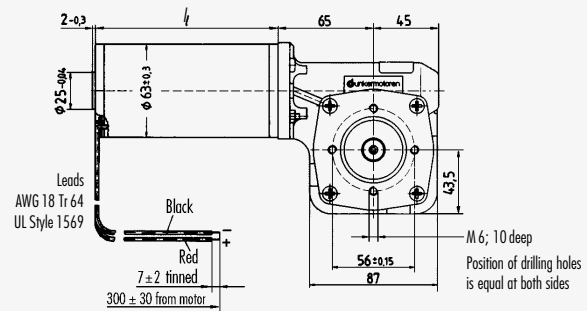

Motor GR 63 with gear SGF 120-B5
in flange version B5

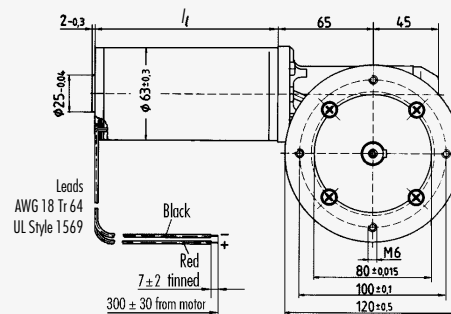

D.C. Gear Motors

Motors with Worm Gears SG

Dimensional drawings · Dimensions in mm

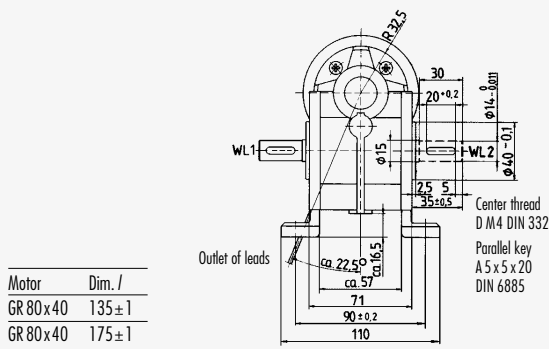

Motor GR 80 with gear SG 120
in foot version B3

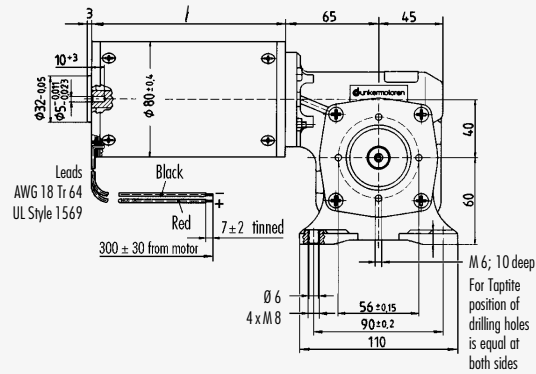

Motor	Dim. l
GR 80x40	135±1
GR 80x40	175±1

Motor GR 80 with gear SGF120-B14
in flange version B14

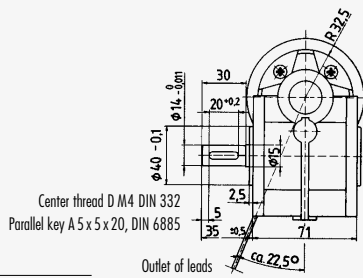

Motor	Dim. l
GR 80x40	135±1
GR 80x40	175±1

Motor GR 80 with gear SGF120-B14
in flange version B14

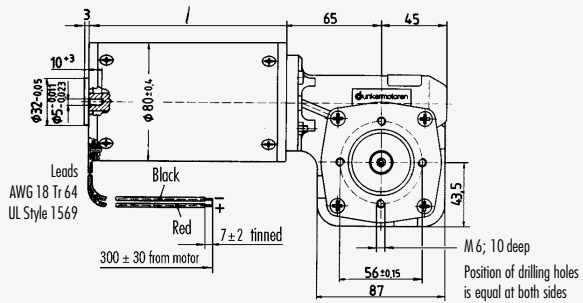

Motor	Dim. l
GR 80x40	135±1
GR 80x40	175±1

Motor GR 80 with gear SGF120-B5
in flange version B5

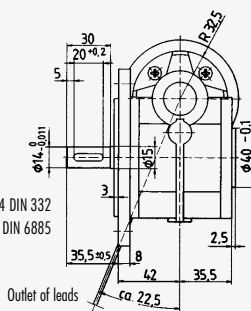

Motor	Dim. l
GR 80x40	135±1
GR 80x40	175±1

Motor GR 80 with gear SGF120-B5
in flange version B5

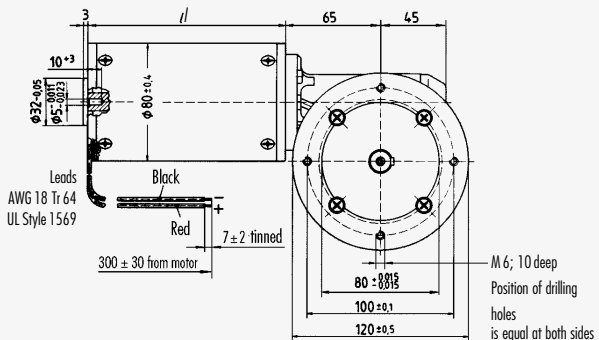

Gleichstrom-Getriebemotoren

Motor GR 63 mit Getriebe-Kombination SG 80 und PLG 52.0

Gear unit types

Worm gear SG 80 with Planetary gear PLG 52.0

PLG for continuous torques

1 stage up to 120 Ncm

2 stages up to 800 Ncm

3 stages up to 2 400 Ncm

PLG-Shaft load capacity axial 500 N max.

PLG-Shaft load capacity radial 350 N max. applied in center point of parallel key

Total Ratio	SG 80-WL1 Ratio :1	PLG 52.0 Ratio :1
22	5	4,5
31	5	6,25
45	10	4,5
62	10	6,25
101	5	20,25
180	5	36
250	5	50
360	10	36
500	10	50
750	15	50
1 200	24	50
1 900	38	50
2 500	50	50
4 000	10	400
6 000	15	400
9 600	24	400
15 200	38	400
20 000	50	400
30 000	75	400

Further ratio combinations on request.

Dimensional drawings - Dimensions in mm

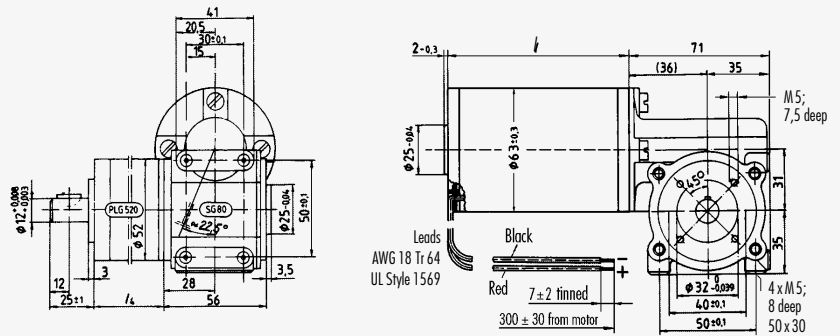

Motor	Dim. l	Dim. l ₄
GR 63x25	95±0,8	-
GR 63x55	125±0,8	-

Gear PLG 52.0	Dim. l	Dim. l ₄
1 stage	-	50
2 stages	-	65,5
3 stages	-	80,5

Motor GR 63 with gear-combination worm gear SG 80 and planetary gear PLG 52.0

D.C. Motors with Brakes

D.C. motors of the type GR 42, GR 53, GR 63 and GR 80 can be delivered with brakes for the rotor.

Thereby quiescent current brakes represent our standard programme.

Brake type E40

The disc is connected firmly with the rotor. As coil support a plastic part is placed over an E-core of dynamo sheet iron.

The braking occurs when no current is flowing by pressing the disc and the plate against each other by means of the springs.

The activated electromagnet pulls the brakeplate and the brake opens.

Brake type E90 R

The E 90 power-off brake can be used with the entire range of Dunker motors (AC,DC,BG).

The spring-loaded brake is applied when its power supply is cut off. By applying the operating voltage, the brake is released. The brake is designed as a steady-current brake.

The brake's special design makes it suitable for both static and dynamic applications.

Axial play in the motor has no influence on the function of the brake. Manual release, such as is often required in emergencies, is available as an option.

Performance data			
Brake type	E 40	E 90	
Application	GR 42	GR 53, GR 63, GR 80	
Rated voltage U_N	24 1)	24	V ₋
Current consumption I_N	308	400	mA
Power consumption P	7,4 VA	9,6 W	—
Resistance	76	60	—
Brake torque M_B	14	100	Ncm
Protection class	IP 20	IP 20/IP 54 3)	IP 20
Class of insulating material	B	"E	—
Lifetime ²⁾	2×10^6	—	Brake cycles
Brake path max. ²⁾	2	—	Revolutions
Switching max.	60	—	Brake cycles/min.
Weight	0,2	0,5	kg

1) Other voltages on request.

2) Without consideration of the moment of inertia of the load.

3) In case of IP 54 version, manual release is not available.

Attention!

- Use of a flyback shunt diode is recommended to protect the D.C. relay contacts of your control unit from contact burn.
- Pay attention to the connection polarity: Plus = red, Minus = black!
- Make sure that no metal shavings or other particles attracted by permanent magnets find their way onto the friction surfaces.
- Keep the friction surfaces free from oil and grease.

- The quoted torque values are applicable once the motor is run in; in its new condition, lesser values are possible.
- The service life depends on the load, the speed and the employed drive. The moment of inertia in loaded condition runs linearly and the speed quadratically in the service life calculation.



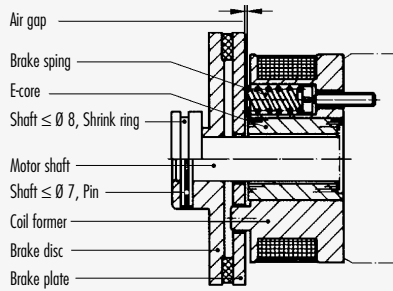

Brake type E40

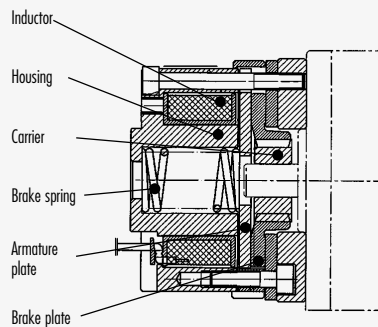

Brake type E100 R

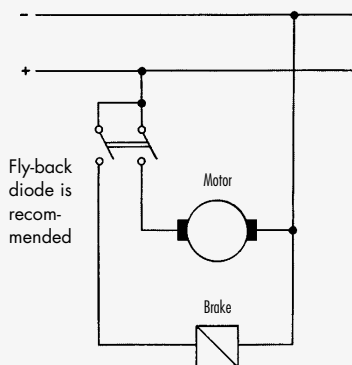

For the feeding of the motor and brake from the same power supply this circuit should be considered.

Dimensional drawings - Dimensions in mm

Motor	Dim. l_1	Dim. l
GR42x25	118±2	70±2
GR42x40	133±2	85±1

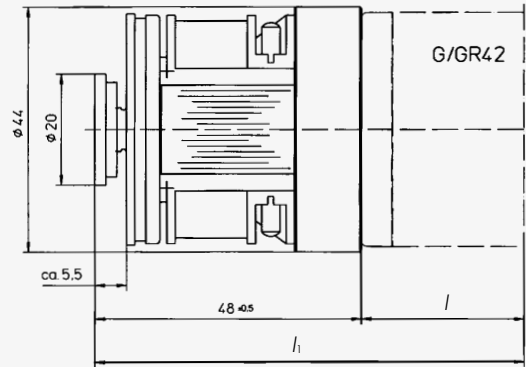

Motor GR42 with brake type E40

Motor	Dim. l_1	Dim. l
GR53x30	135±2	95±1
GR53x58	165±2	125±1
GR63x25	135±2	95±1
GR63x55	165±2	125±1
GR80x40	175±2	135±1
GR80x80	215±2	175±1

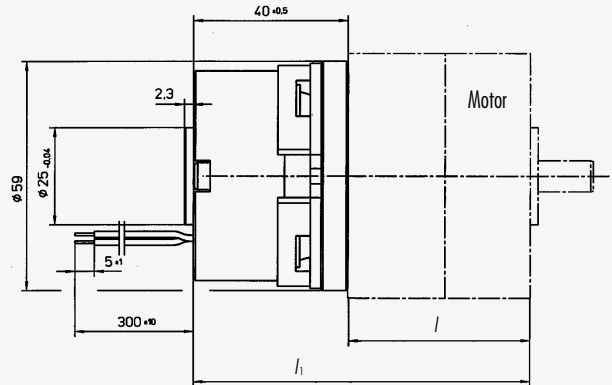

Motors GR53, GR63, GR80 with brake type E90

Brake type E90 with IP-cover and connector

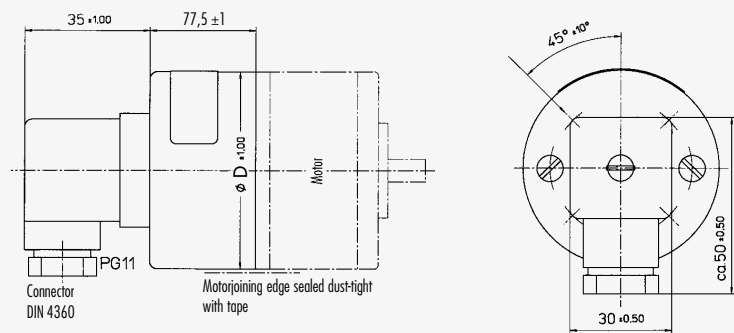

Motor	Ø D
GR53	52 ± 1,0
GR63	63 ± 1,0
GR80	80 ± 1,0

The GR 53, GR 63 and GR 80 series can be supplied with IP-housing and connector.

Components for D.C. Motors with Speed Control

Actual value generators

GR series D.C. motors can be equipped with analog or digital actual value generators for measuring the actual RPM.

Combination possibilities

Due to the modular design of the drive units it is possible to combine tachogenerators, value generators and/or brakes.

Please contact us for your special application.

Combination possibilities of motors, generators and electronic control systems							
Istwertgeber bzw. Drehzahlgeber	Increments channels	Motor GR 22.0	Motor GR 26.0	Motor GR 42	Motor GR 53	Motor GR 63	Motor GR 80
Tachogenerator TG 11	analog	–	–	●	●	●	●
Tachogenerator TG 52	analog	–	–	–	●	●	●
Inkremental encoder RE 30-2-500	2-channel 2x500 pulse	–	●	●	●	●	●
Inkremental encoder RE 30-3-500	2-channel 2x500 pulse with reference pulse	–	●	●	●	●	●
Inkremental encoder RE 56	2-channel 2x1000 pulse	–	–	●	●	●	●
Magnetic pulse generator MG 2-2	2-channel 2 Impulse	–	–	○	○	○	○
Magnetic pulse generator ME52-2/12	2-channel 2/12 pulse	–	–	●	●	●	–
Magnetic pulse generator ME 80-2/12	2-channel 2/12 pulse	–	–	–	–	–	●
Electronic control RS 200	–	–	–	●	●	●	●
Electronic control RS 400	–	–	–	●	●	●	●

○ On request.

Components for D.C. Motors with Speed Control

Analog Value Generators – Tachogenerators TG 11 and TG 52

D.C. Tachogenerators TG 11 and TG 52

The D.C. tachogenerators TG 11 and TG 52 can be used as actual value generators for speed control of D.C. motors; in doing so the tachometer systems are suitable for large control ranges and very low control speeds.

The tachogenerators are rigidly built and do not require maintenance during their lifetime.

The numerous slots of the D.C. tachogenerator rotor guarantee a low residual ripple.

Tachogenerator	TG 11	TG 52	
Rotor	9 slots	17 slots	–
Number of pole pairs	–	1	–
D.C. resistance	68	140 ± 15%	Ω
Induced voltage	3,0	10	V/1000 min ⁻¹
Moment of inertia <i>J</i>	8,5	92	g cm ²
Temperature coefficient	–0,25	–0,01	% / °C
Weight <i>m</i>	80	380	g

Dimensional drawings · Dimensions in mm

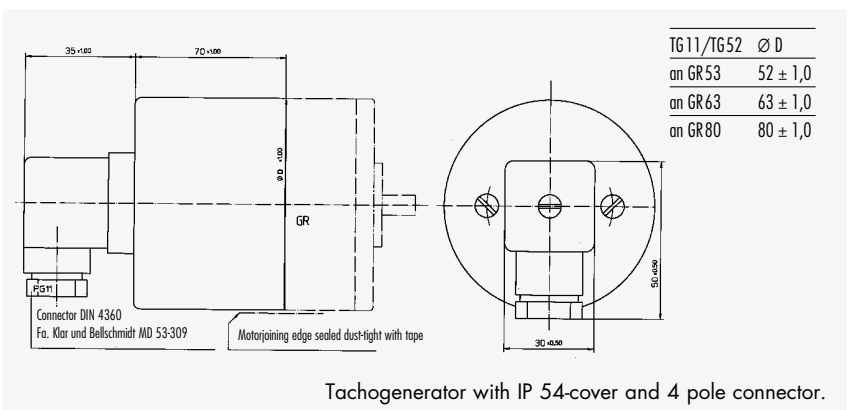
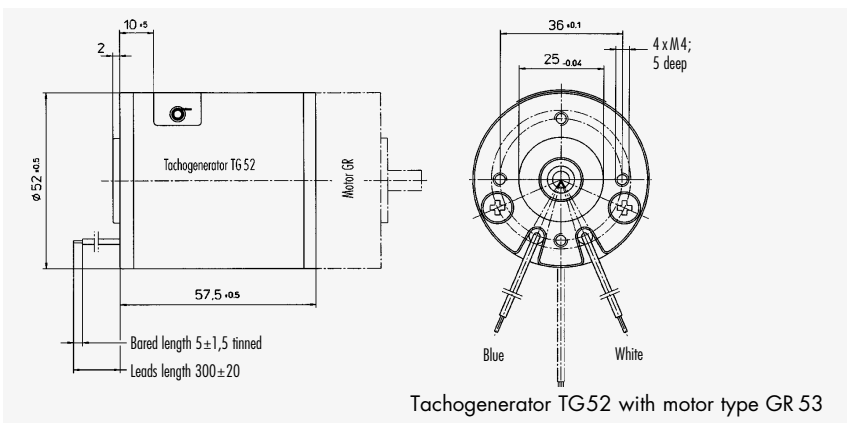
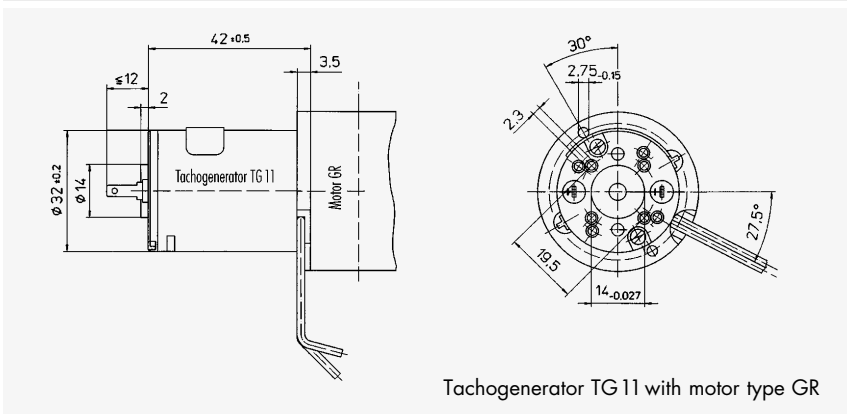

Components for D.C. Motors with Speed Control

Digital Incremental Encoders RE 30-2, RE 30-3 and RE 56

The incremental encoders RE 30 and RE 56 are suitable for speed acquisition resp. speed control of D.C. motors.

The digital rotary encoders are connected mechanically to the motor and transmits a series of impulses corresponding to the motor speed and direction via a 5-pin connector.

Principle of operation

The non-contact speed transmitter is wear-free.

A light barrier is formed by a LED, a metallic slotted disc, and a photodiode array. Internal logic circuitry generates two TTL-compatible square wave signals in phase quadrature from the photodiode signal.

Connection cable

Please order the connection cable with connector for the encoders, see accessories.

Drivers for +5 V and +10 V to +30 V are available.

Digital incremental encoder		RE 30-2
Output signals		2 square wave signal, in phase quadrature TTL-compatible
Impulse count per rotation		500, channels A and B
Supply voltage		+5 V \pm 10%
Supply current		typ. 17 mA; max. 40 mA
Deviation of pulse width ¹⁾		typ. 7° max. 40°
Deviation of phase shift ²⁾		typ. 2° max. 15°
Output voltage	Low level	0,4 V at 3,2 mA (I_L) max.
	High level	2,4 V at 40 μ A (I_H) min.
Rise time $C_L=25$ pF; $R=11$ k Ω		typ. 200 ns
Fall time $U=+5$ V		typ. 50 ns
Load capacity $R^3)$		$C_L=100$ pF max.
Operating temperature range		-40 to 100°C
Protection class		IP 30

Digital incremental encoder		RE 30-3
Output signals		2 square wave signal, in phase quadrature 1 reference signal, TTL-compatible
Impulse count per rotation		500, channels A and B
Supply voltage		+5 V \pm 10%
Supply current		typ. 57 mA; max. 85 mA
Deviation of pulse width ¹⁾		typ. 7° max. 30°
Deviation of phase shift ²⁾		typ. 2° max. 15°
Output voltage	Low level	0,4 V at 3,86 mA (I_L) max.
	High level	2,4 V at 200 μ A (I_H) min.
Rise time $C_L=25$ pF; $R=11$ k Ω		typ. 180 ns
Fall time $U=+5$ V		typ. 40 ns
Load capacity $R^3)$		$C_L=100$ pF max.
Operating temperature range		-40 to 100°C
Protection class		IP 30

Digital incremental encoder		RE 56-2
Output signals		2 square wave signal, in phase quadrature TTL-compatible
Impulse count per rotation		1000, channels A and B
Supply voltage		+5 V \pm 10%
Supply current		typ. 17 mA; max. 40 mA
Deviation of pulse width ¹⁾		typ. 7° max. 40°
Deviation of phase shift ²⁾		typ. 2° max. 15°
Output voltage	Low level	0,4 V at 3,2 mA (I_L) max.
	High level	2,4 V at 40 μ A (I_H) min.
Rise time $C_L=25$ pF; $R=11$ k Ω		typ. 200 ns
Fall time $U=+5$ V		typ. 50 ns
Load capacity $R^3)$		$C_L=100$ pF max.
Operating temperature range		-40 to 100°C
Protection class		IP 30

1) From 180 electrical degrees.

2) Between channel A and B from 90 electrical degrees.

3) $R=3,2$ k Ω against $U=+5$ V "Pull up"

Dimensional drawings · Dimensions in mm

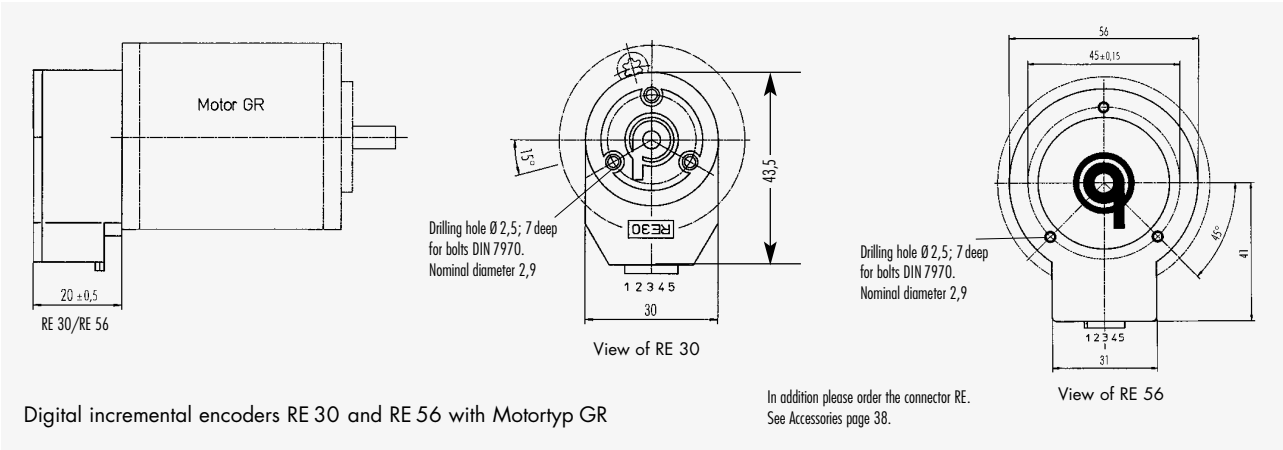

Digital incremental encoders RE 30 and RE 56 with Motortyp GR

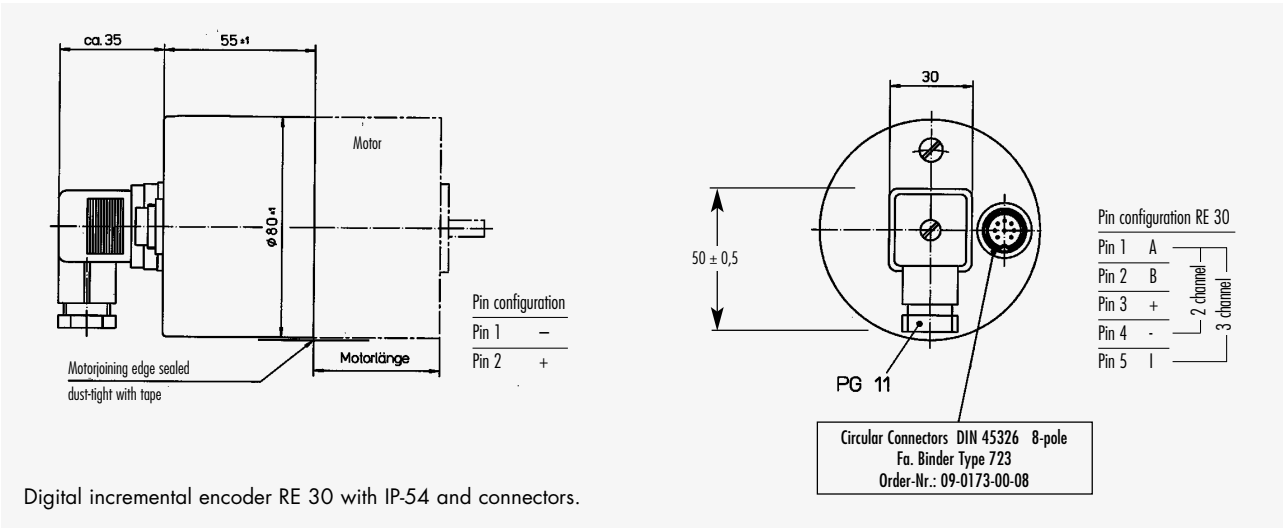

Digital incremental encoder RE 30 with IP-54 and connectors.

Proposal for wiring

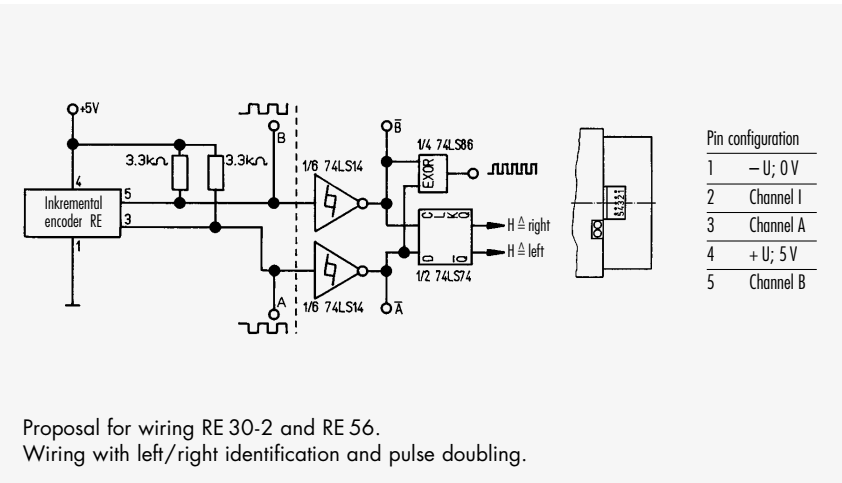
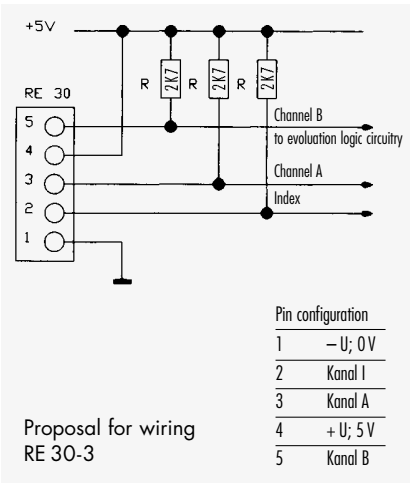

Components for D.C. Motors with Speed Control

**Magnetic Pulse Generator MG 2-2 (Ø 42-cover) for motor GR 42,
ME 52-2/12 (Ø 52-cover) for motors GR 53, 63
and ME 80 for motor GR 80**

The magnetic pulse generators are applicable for speed detection, speed control and positioning in combination with corresponding electronics.

The magnetic pulse generators are connected mechanically to the motor and transmit a series of impulses corresponding to the motor speed and direction via external leads.

Principle of operation

The non-contact magnetic generator is equipped with hall sensors and magnet ring and is wear-free. A safe operation is possible due to the simple design, the magnetic signal activation and the starting signal which can be varied by the supply voltage.

Magnetic pulse generator	MG 2-2 / ME 52-2/12 / ME 80-2/12
Output signals	2 square wave signals, in phase quadrature
Impulse count per rotation	2/12, channels A and B
Supply voltage	5 V min; 24 V max.
Supply current	12 mA max. bei $U=12V$
Deviation of pulse width 1)	10° max. / 30° typ
Deviation of phase shift 2)	10° max. / 40° typ
Output voltage, low level	0,4 V max. bei $U=12V$; $I=20\text{ mA}$; $T_I \leq 100^\circ\text{C}$
Rise time $U=12V$; $R_L=820\ \Omega$	85 ns typ; 400 ns max.
Fall time $C_L=20\ \text{pF}$	60 ns typ; 400 ns max.
Operating temperature range	-40 bis 85°C

1) From 180 electrical degrees. 2) Between channel A and B von 90 electrical degrees.

Dimensional Drawings · Dimensions in mm

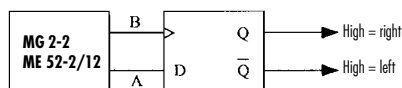
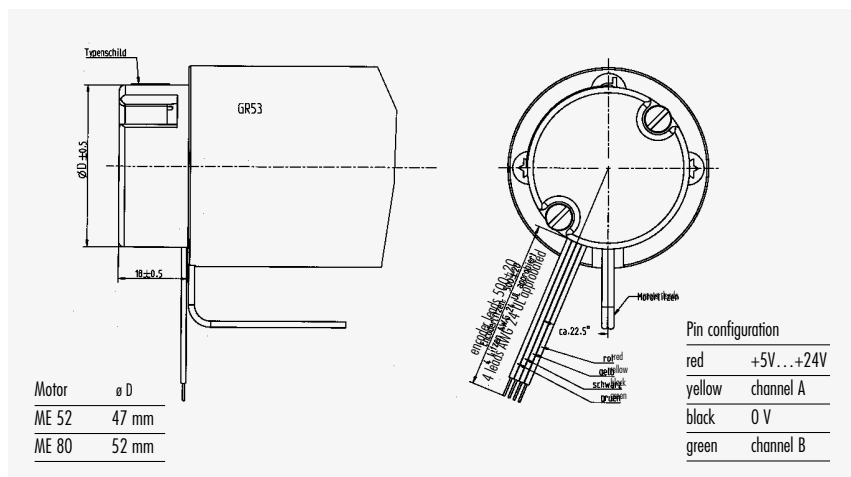
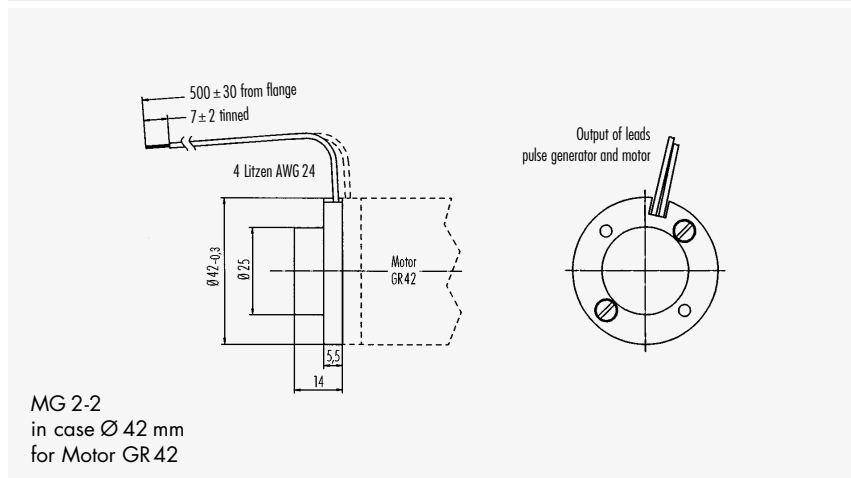

Proposal for wiring
Right-/left detection

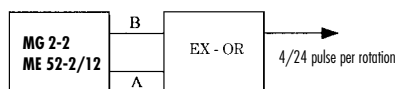

Proposal for wiring
Pulse doubling

Accessories

Safety cover and Connectors RE and Circular Connectors

The GR 53, GR 63 und GR 80 series D.C. motors can be supplied equipped with safety covers and connectors.

The safety cover is supplied in different lengths to accommodate designs without fittings on the non-drive side, or designs which have braking units or tacho generators mounted.

Cover diameter and length $D\varnothing \times L$

Motor-Type	Without fittings $D\varnothing \times L$ mm
GR42	42x20
GR 53	52x25
GR 63	63x22
GR 80	80x22

Circular connectors for safety covers IP

Dimensions in mm

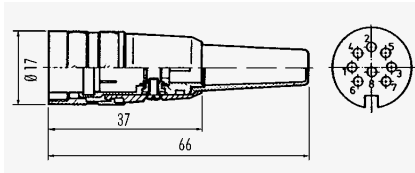

Coupling with screw plug

Protection class IP 40

8pole, DIN 45326

Order-No. 24320 57001

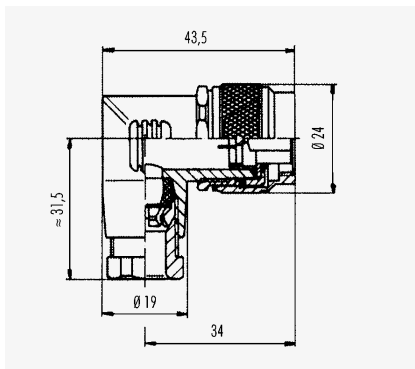

Angled housing with screw plug

Protection class IP 65, watertight

8pole, DIN 45326

Order-No. 24320 57000

Dimensional drawings · Dimensions in mm

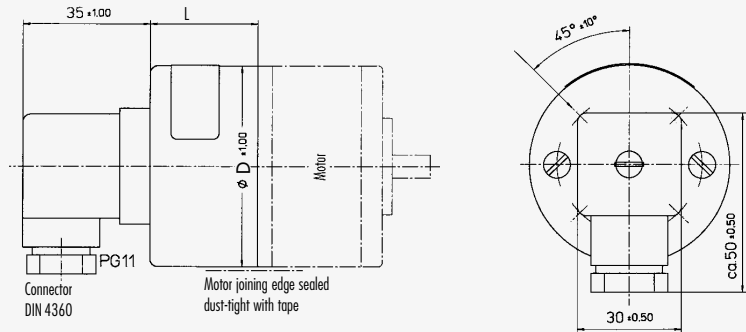

Motor with safety cover and connector

Pin configuration for Motor with brake/tacho

Connector 1

Connector 2

- Motor

+ Motor

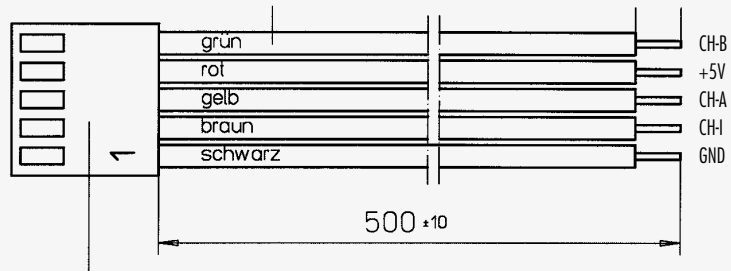

Connector Molex, 5 pole, Typ 5051 M

with female contacts type 2759 for shell 5051 M

Order-No. 22-01-1053

Order-No. 08-50-0113

Connector Elco, 5 pole, Typ 8263

with female contacts for shell 8263

Order-No. 60-8263-3058-15-001

Order-No. 60-8263-0523-99-808

Stranded wire AWG 24

UL-approved 7 or more tinsel conductors, tin-plated Isolation diameter max. 1,57. Tear out force of stranded wire ≥ 20 N!

Connector RE with cable for

RE 30-2, RE56-2, RE30-3 and RE 56-3

Order-No. 27573 37026

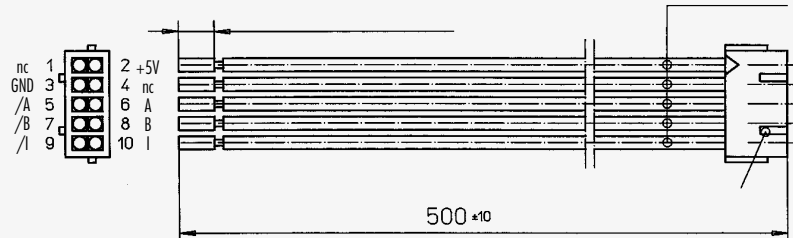

Stranded wire AWG 24

UL-approved 7 or more tinsel conductors, tin-plated Isolation diameter max. 1,57. Tear out force of stranded wire ≥ 20 N!

Connector IST PHDR-10VS

Connector RE with cable for RE 30-3-TI

Order-No. 27573 37059

Electronic Control Systems

The electronic controller serves for speed control of permanent magnetic DC-motors.

Electronic controller RS 200

The RS200 electronic controller is designed for speed control of permanent magnetic DC-motors in single quadrant operation. It delivers a starting voltage adjustable from 0 to the nominal voltage at constant current direction.

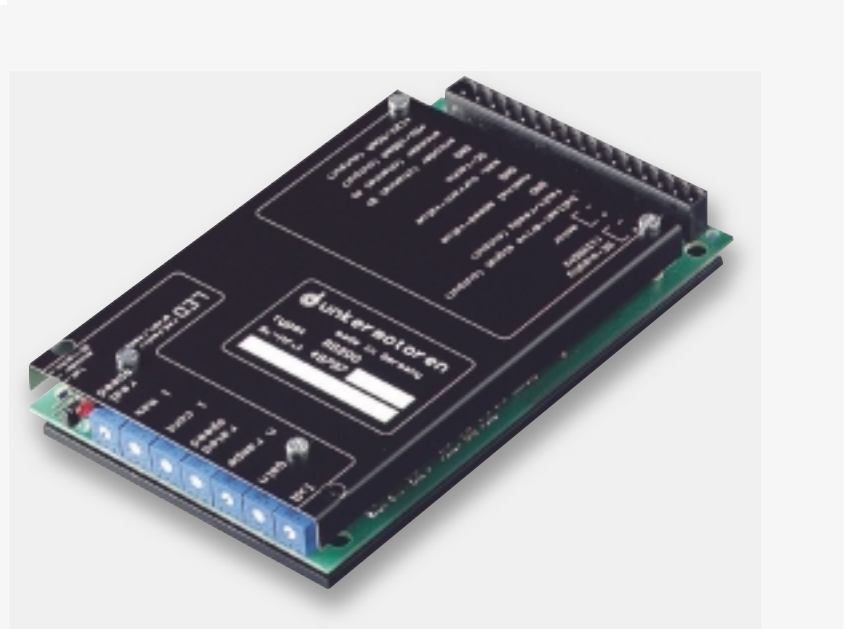

2-quadrant-electronic controller RS 200

Electronic controller RS 400

The RS 400 electronic controller is designed for speed control of permanent magnetic DC-motors in 4-quadrant operation.

It is a 4-quadrant controller with well-defined torque and direction change characteristics.



4-quadrant-electronic controller RS 400

Electronic Control Systems

2Quadrant Speed Controller RS 200

The RS200 electronic controller is a transistor servo-controller for brushed permanent-magnet DC motors. The RS200 electronics enables a motor to drive and brake in one direction (2-quadrant operation). The braking effect is achieved by short-circuit braking.

The RS200 servo-controller is an analogue speed regulator that operates on a current-regulation basis. The pulse-width-modulated electronics have a high efficiency and are thus very compact. To ensure compliance with current EMC standards, a filter is included, and the controller has a complete electromagnetic protected housing. These features combined with the use of shielded cables ensure that the requirements of EN55011 Cl. B are fulfilled. There is also a fuse on the PCB which interrupts the mains supply if overloaded.

The RS200 electronic controller only needs a single supply voltage that lies within a generous range. All necessary auxiliary voltages, including those for supplying external components are generated from this internal power-supply.

The user has a choice of methods of providing the actual-speed signal, either with a DC tachogenerator, a one or two-channel rotary encoder, or by using the speed-proportional EMC of the motor with compensation for the current-dependent armature-voltage drop (IxR). To select the desired type of operation (DC tachogenerator, encoder or IxR), the user simply has to put a bridging plug in the correct place in the connector strip. For applications with less stringent demands on speed control (above 500 1/min), it is possible to set speed substantially independent of load by using EMC without the need for a DC tachogenerator or encoder.

This EMC regulation is a low-cost solution and is also economical on space. For speeds of rotation above 50 1/min, speed feedback can be achieved using

Electronic controller	RS 200
Supply voltage	12V = U = 50V with max. 5% ripple
Under/overvoltage protection	for 10 V > U > 60 V
Auxiliary voltage	+5V/100mA and +12V/40mA
Ballast circuit	5Watt effective for 54V < U < 57V, externally extendable
Maximum continuous current	0 < I < 7A adjustable
Maximum dynamic current	0 < I < 15A adjustable
Fuses	8A (MT) installed
DC-tacho voltage	rotary incre- 0 to +60V
mental encoder	5V auxiliary supply generated and automatic evaluation of 1 or 2-channel square-wave signals
Recommended operating range	<ul style="list-style-type: none"> - with RXI regulation minimum speed of rotation: 500 1/min - with rotary incremental encoder (e.g. RE30) minimum speed of rotation: 50 1/min - with tachogenerator (e.g. TG11) minimum speed of rotation: 5 1/min
Accuracy of regulation	by Speed loading from 0 to 80% of torque <ul style="list-style-type: none"> - with IxR regulation 10% - with rotary encoder (e.g. RE30) 1% - with tachogenerator (e.g. TG11) 1%
Max. speed of rotation	6000/min
Speed-target ramp	adjustable from ca. 0 - 10 s
P-speed-control amplification	0 < Pn < 9 adjustable
Heat-sink temperature	max. 80°C, thereafter current is automatically adjusted
Interference suppression	to EN55011 Class B
Protection class	IP00
Ambient temperature	0 ≤ θ ≤ 40°C
Dimensions	(163 x 100 x 28) mm

the RE30 or RE56 rotary encoders. The widest speed-control range with the greatest precision of regulation is achieved by using one of the DC tachogenerators TG11 or TG 52. For specific projects, use of the MG2 sensor is also possible.

When the servo-controller is ready for operation, a LED indicator is illuminated, and there is also a digital output signal. Where it is necessary to

use an external ballast circuit, there is a suitable signal available at the connector to the PCB.

For connecting the servo-controller, there is a 16-pole phoenix-style connector with screw/plug terminals (available as an accessory). For specific projects, the RS200 electronic controller can be supplied with a 32-pin strip to DIN41612 so that it is suitable for use in 19"-racks.

Block diagram RS 200

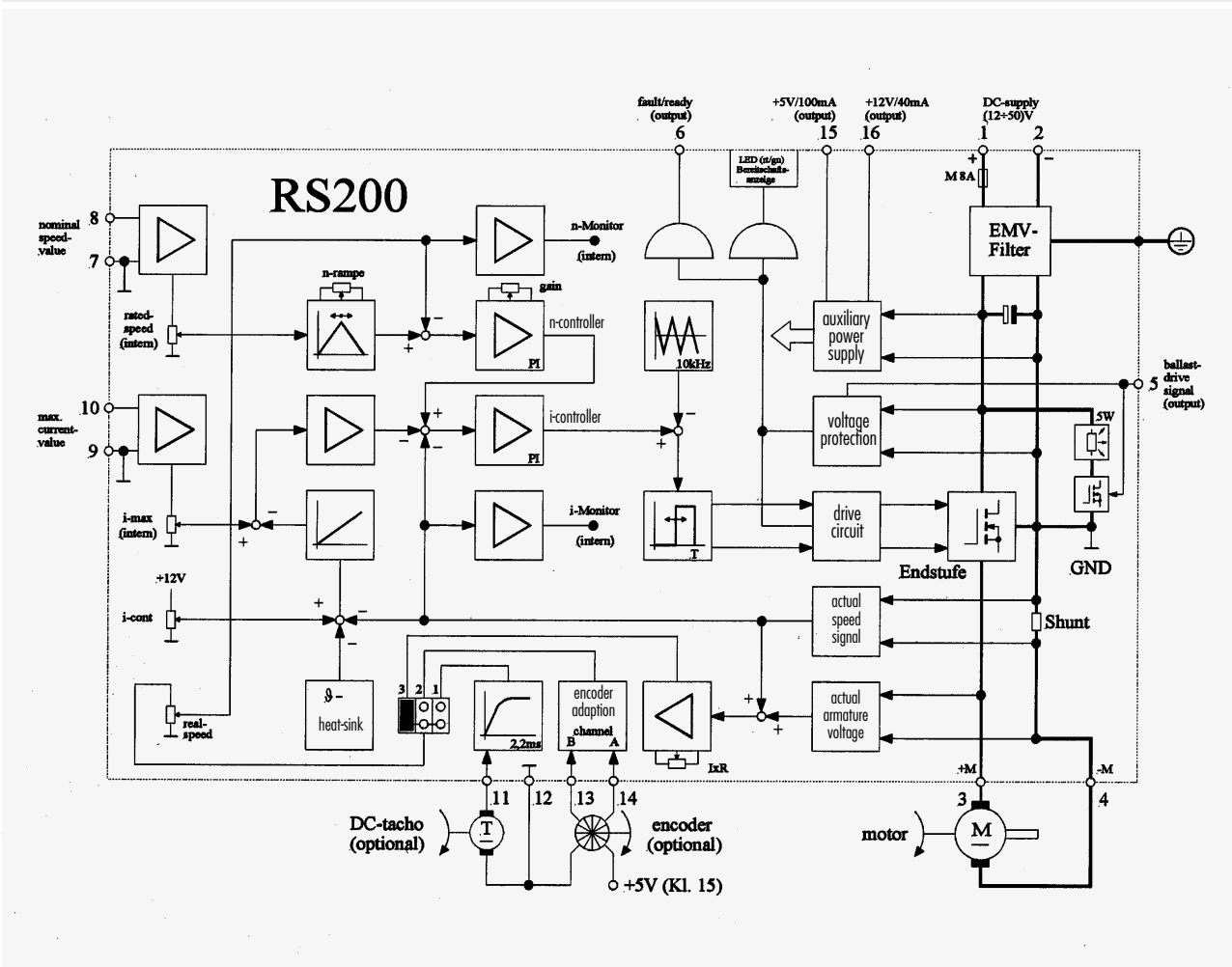

Potentiometerarrangement

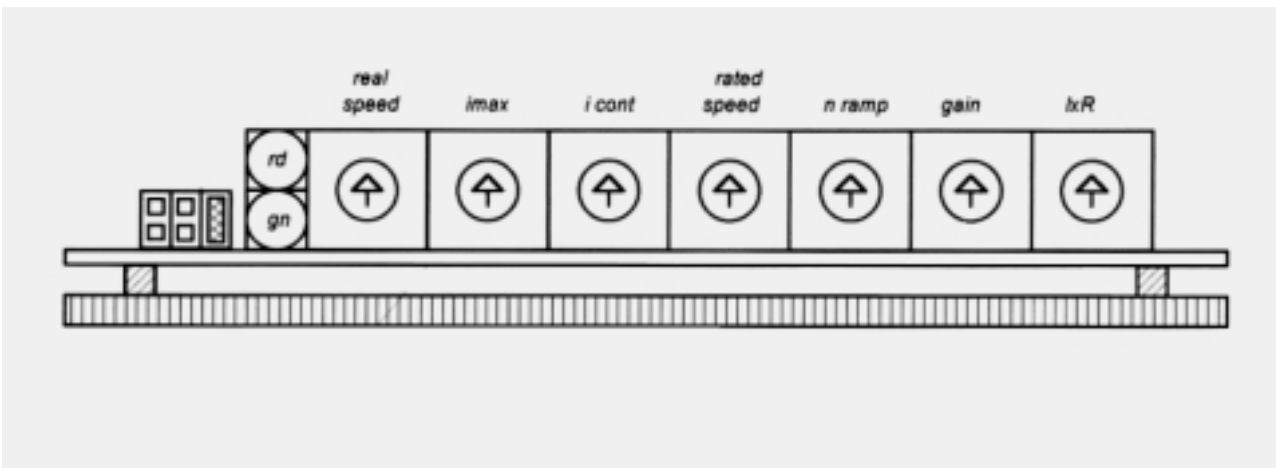

Electronic Control Systems

4 Quadrant Speed Controller RS 400

The RS 400 electronic control system is a transistorised servocontroller designed for use with permanent magnet D.C. motors. It is a 4 quadrant controller with welldefined torque and direction-change characteristics.

The RS 400 servocontroller is used as a speed regulator with current control.

Pulse width modulation is used to achieve high efficiency and low heating losses, making the unit extremely compact.

Switching losses are further reduced by the fact that although the motor is clocked at an inaudible 20 kHz, each transistor in the output stage is clocked at half the motor frequency.

During a no-load motor standstill, the motor is deenergised, thus preventing the motor from overheating.

The RS 400 electronic control system requires only one supply voltage, from which all other necessary auxiliary voltages are generated. Providing the power supply for the servo regulator is therefore simple and inexpensive.

The RS 400 servocontroller permits exact speed control by feeding the motor speed back to the unit via either a D.C. tachogenerator or a two-channel incremental encoder.

For applications where the speed control accuracy is of secondary importance, I x R regulation also achieves a largely load-independent speed control without use of the D.C. tachogenerator or rotary encoder.

Electronic control system	RS 400
D.C. supply voltage	24 V _{DC} < U < 50 V _{DC}
Supply voltage ripple max.	5% max.
Rated motor current	6 A
Peak motor current adjustable	Up to 2.5 times the rated current a) internally by potentiometer b) externally by voltage
Input voltage range of peak motor current	0 < u < +12 V for external setting
Offset adjustment of speed control	Adjust for motor standstill
Proportional sensitivity of speed control	Adjustable between 1 and 9
Adaptation of actual motor speed	Via internal potentiometer
I x R compensation	Via potentiometer
Speed reference value adjustable	a) internally by potentiometer b) externally by a voltage on the input of a differential amplifier
Input voltage range of speed reference value	-12 V < u < +12 V for external setting
Feedback of actual value of motor speed	a) with D.C. tachogenerator or b) incremental encoder with 2 square wave signals, phase offset 90°
Input voltage for D.C. tachogenerator	75 V max.
Supply voltage for 2-channel incremental encoder	5 V, available on the RS 400
Blocking of output stage	With a voltage of 12 V at control input
Continuous power dissipation of ballast circuitry	5 W
Turn-on threshold of ballast circuitry	58 W
External auxiliary ballast circuitry	Connection by a 31 pin connector
Intermediate circuit voltage	a) at 62 V the output stage will be blocked b) at 65 V the whole system shuts down
Heat sink temperature	At 80°C ± 5% the output stage will be blocked
Operation after the intermediate circuit voltage or heat sink temperature	Only possible after switching off the power supply to the entire control board for several seconds
Dimensions of euro card	100 x 160 mm, overall height 35 mm
Protection class	IP 00
Connection according to DIN 41617	By 31 pin connector
Installation position	Cooling ribs in vertical position with unhindered convection
Weight	330 g

The maximum current and reference speed can both be set either at the control board or externally.

Adapting the electronic control system to the application on hand is a simple matter of applying shorting jumpers to an 8-pin jumper connector on the operating side without soldering. Blocking the output stage can be externally controlled.

The ease with which the TS servo-controller can be externally adjusted makes it ideal for use in systems requiring high accuracy such as position controller, etc.

Jumper configuration

The configuration of the jumper connector is determined by the individual application, and also determines the type of motor feedback used and the setting of the speed reference value, internally or externally.

Speed reference value

Setting the speed reference value internally

Setting the speed reference value externally

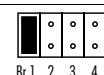
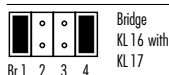

Speed control with D.C.tacho

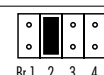
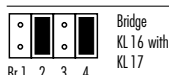

Speed control with 2-channel incremental encoder

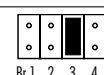

Speed control with $I \times R$ regulation

Configuration of 31 pin connector

Pin	Designation	Comment
1	Incremental encoder channel A	Leading signal input for clockwise motor rotation
2	Incremental encoder channel B	90° lagging signal input for clockwise motor rotation
3	Auxiliary voltage +5 V	Supply voltage for incremental encoder
4	0 V	0 V common
5	D.C.tacho voltage -	Input voltage from D.C.tacho for clockwise motor rotation
6, 7	Connection ballast circuitry	External auxiliary ballast circuitry
8	Control ballast circuitry	Output voltage for control of external auxiliary ballast circuitry
9, 10	Auxiliary voltage +12 V	Output is not heavily loadable
11, 12	0 V	0 V common
13, 14	Auxiliary voltage -12 V	Output is not heavily loadable
15	Output stage blocking	Input voltage +12 V for blocking of output stage
16	0 V/D.C.tacho voltage +	0 V common
17	Differential input + für speed reference value	Input voltage -12 V to +12 V
18	Differential input - für speed reference value	Input voltage -12 V to +12 V
19	External setting of peak motor current	Input voltage 0 V bis +12 V
20, 21, 22	Supply voltage +	Input voltage
23, 24, 25	Supply voltage -	0 V common
26, 27, 28	Motor connection +	For clockwise rotation: plus to plus and minus to minus
29, 30, 31	Motor connection -	

Electronic Control Systems

4 Quadrant Speed Controller RS 400

Block diagram RS 400

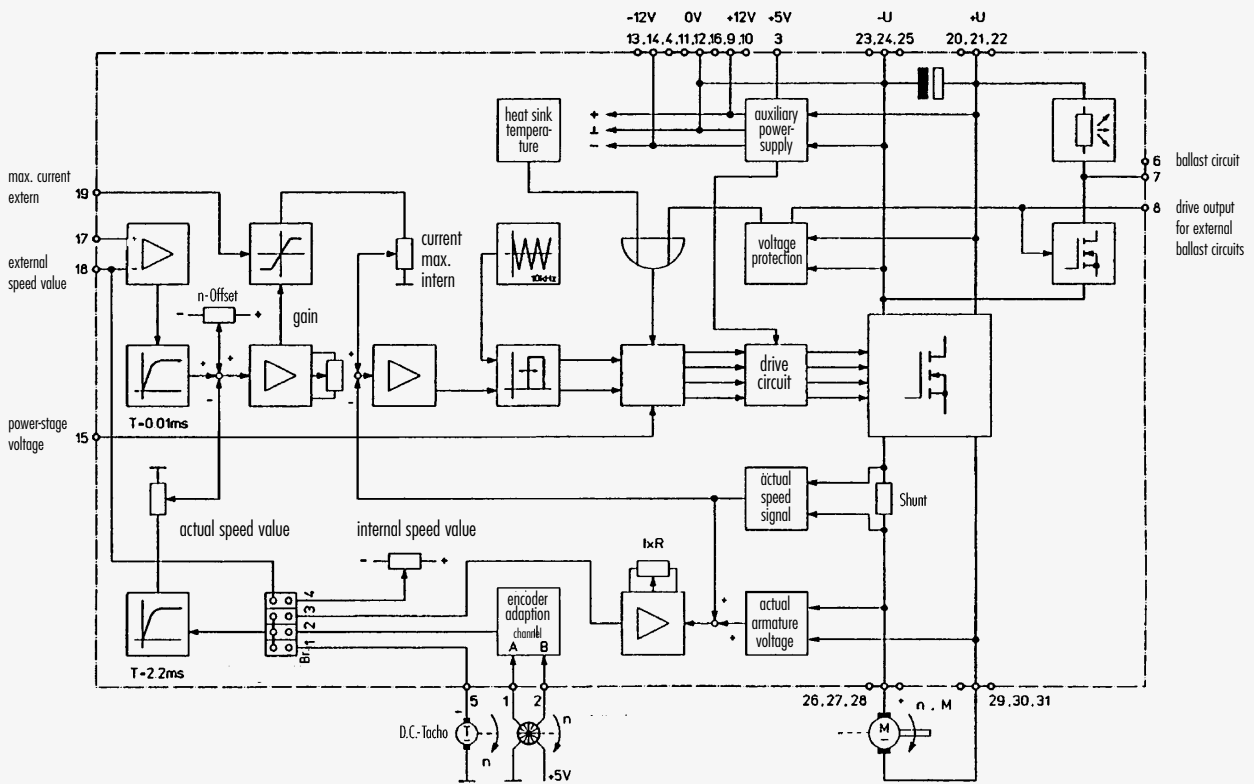

Our Delivery Program

Dunkermotoren – Small Precision Motors

Dunkermotoren offers the optimal solution for many drive problems in form of A.C. and D.C. motors which can be combined with a great variety of gears.

For further information please contact our agent or us directly.

Alcatel SEL AG
Components Division
Dunkermotoren
Allmendstrasse 11
D-79845 Bonndorf, Schwarzwald
<http://www.dunkermotoren.de>
e-mail: info@dunkermotoren.de
Telefax (077 03) 9 30-2 10/2 12
Telephone (077 03) 9 30-0

Electronic D.C. Motors

Electronic D.C. Motors BG

Operating voltage	12 – 60 V
Operating speed	2700 – 3650 min ⁻¹
Torque max.	9,7 – 110 Ncm

As accessory for brushless D.C. motors different electronic control units are available. The BG motors can be delivered with armature brakes.

All BG motors can be produced in series with planetary-, spur- and worm gears.

D.C. Motors

D.C. Motors G

Operating voltage	3 – 40 V
Operating speed	1500 – 6000 min ⁻¹
Torque max.	0,85 – 5,6 Ncm

D.C. Motors GR

Operating voltage	3 – 220 V
Operating speed	1500 – 10000 min ⁻¹
Torque max.	0,47 – 70 Ncm

All D.C. motors can be produced in series with planetary-, spur- and worm gears.

A great share of the motors is deliverable with armature brakes.

The GR motors are obtainable with analogue or digital encoders.

A.C. Motors

Three-phase Motors DR

Operating voltage	230/400 V, 50 Hz
Nominal power	6 – 86 W
Nominal torque	4,1 – 32 Ncm
Motor version	2/4poles

Single-phase Capacitor Motors KD

Operating voltage	230 V, 50 Hz
Nominal power	2 – 76 W
Pull-out torque	0,75 – 28 Ncm
Motor version	2/4poles

All A.C. motors can be produced in series with planetary-, spur- and worm gears.

A great share of the motors is deliverable with armature brakes.

Venetian Blind and Positioning Drives

Venetian Blind Drives

Operating voltage	230 V, 50 Hz
Operating speed	23 min ⁻¹
Torque max.	3 – 10 Nm bzw. 2 x 4,5 – 2 x 10 Nm

Positioning Drives

Operating voltage	230 V, 50 Hz
Operating speed	11, 23 bzw. 52 min ⁻¹
Torque max.	bis 20 Nm

The complete drive consists of:

- Single-phase capacitor motor
- Planetary gear
- Integrated final position switch
- Electromagnetic brake and temperature sensor

Electronic Control System DSC

Dunkermotoren has developed a new control system for the venetian blind motors.

The control system DSC is a decentralized system for the control of venetian blind single-phase capacitor motors.

The system contains:

- Control power supplies
- Individual control units
- Group control units
- Group switches
- Central control units

REPRESENTATIVES AND DISTRIBUTORS

GERMANY

Sachsen, Thüringen, Sachsen-Anhalt
Spezialantriebstechnik GmbH
Roland Kühnel
Postfach 49 · 04744 Hartha
Tel. (034328) 41374 · Fax (034328) 39238
e-mail: spatgmbh@t-online.de

Berlin, Brandenburg, Mecklenburg
Z & B GmbH
Herr John
Weststr. 1 · 13405 Berlin
Tel. (030) 4170 7520 · Fax (030) 4170 7575
e-mail: mail@zub.de · Internet: www.zub.de

Niedersachsen, Hessen Nord, Westfalen Ost
Ingenieurbüro Heinrich Jürgens
Roggenhof 5 · 31787 Hameln
Tel. (05158) 98098 · Fax (05158) 98099
e-mail: ingenieurbuero.juergens@real-net.de

Hamburg/Bremen, Schleswig- Holstein,
Niedersachsen Nord
Technisches Büro Kühling/Merten
Gutenbergring 67c · 22848 Norderstedt
Tel. (040) 5234098 · Fax (040) 5282476
e-mail: Kuehling-Merten@t-online.de

Ruhrgebiet
Lothar Amborn
Fasanenstrasse 21b · 45134 Essen-Stadtwald
Tel. (0201) 443500 · Fax (0201) 443501
e-mail: lothar.amborn@t-online.de

Rheinland
Ingenieurbüro Horst Schlote KG
Kalkbitze 14 · 53783 Eitorf-Oberroth
Tel. (02243) 4447 · Fax (02243) 811 95
e-mail: horst.schlote@arcormail.de

Hessen
Antriebstechnik Eberhardt GmbH
Landgrabenstrasse 21 · 61118 Bad Vilbel
Tel. (06101) 500316
Fax (06101) 500318
www.antriebstechniken.de/eberhardt
e-mail: Eberhardt@antriebstechniken.de

Rheinland-Pfalz, Saarland
Dieter Brems
Burgunder Strasse 35 · 55278 Mommenheim
Tel. (06138) 1366 · Fax (06138) 1335
e-mail: dieter.brems@t-online.de

Bayern Nord
Ingenieurbüro für Elektrotechnik GmbH
Dipl.-Ing. Christleven
Preuschwitzerstr. 38 · 95445 Bayreuth
Tel. (0921) 41360 · Fax (0921) 46192
e-mail: info@christleven.de
Internet: www.christleven.de

Bayern Süd
Antriebstechnik Quin GmbH
Herr Ferdinand Quin
Lärchenstrasse 1 · 85604 Zorneding
Tel. (08106) 247170 · Fax (08106) 247171
e-mail: info@atq.de · Internet: www.atq.de

Württemberg
Technisches Büro Späth
Eyachstrasse 37 · 71065 Sindelfingen
Tel. (07031) 794 34-60 · Fax (07031) 794 34-70
e-mail: tb.spaeth@t-online.de

Baden
Büro für Antriebstechnik
Frieder Hertweck
Mooswaldstr. 8 · 79279 Vörsstetten
Tel. (07666) 4188 · Fax (07666) 7343
e-mail: antriebstechnik.hertweck@t-online.de

EUROPE AND OVERSEAS

Austria
Ing. Franz Schmachtl KG
Postfach 362 · Pummererstrasse 36 · 4021 Linz
Tel. (0732) 76460 · Fax (0732) 785036
www.schmachtl.at
e-mail: office.linz@schmachtl.at

Ing. Franz Schmachtl KG
Theodor-Körner-Strasse 54 · 8010 Graz
Tel. (0316) 672185 · Fax (0316) 672439
e-mail: office.graz@schmachtl.at

Ing. Franz Schmachtl KG
Arzlerstrasse 43 A · 6020 Innsbruck
Tel. (0512) 265060 · Fax (0512) 266151
e-mail: office.ibk@schmachtl.at

Ing. Franz Schmachtl KG
Postfach 187 · 1230 Wien
Tel. (01) 6162180 · Fax (01) 616218099
e-mail: office.wien@schmachtl.at

Belgium / Luxembourg
Elmeq BVBA
Jacob Lacopsstraat 16 · 9700 Oudenaarde
Tel. (055) 319901 · Fax (055) 319080
e-mail: info@elmeq.be

Czechlands
Schmachtl CS
Videnská 185 · 25242 Vestec-Praha
Tel. (02) 44 00 15 00 · Fax (02) 44 91 07 00
www.schmachtl.cz
e-mail: office@schmachtl.cz

Denmark
Compower A/S
Smedeholm 13B · 2730 Herlev
Tel. 44926620 · Fax 44926602
e-mail: info@compower.dk
Internet: http://www.compower.dk

Finland
Wexon OY
Juhaniantie 4 · 01740 Vantaa
Tel. (09) 290 440 · Fax (09) 290 44100
e-mail: Wexon@wexon.fi
Internet: http://www.wexon.fi

France
MDP
21 Porte du Grand Lyon, Neyron
01707 Miribel Cédex
Tel. (4)72 018300 · Fax (4)72 018309
e-mail: mdpcontact@moteur-diffusion-partner.fr
Internet: http://www.moteur-diffusion-partner.fr

Great Britain
Alcatel Dunkermotoren, Div. of AVT
140 Lower Green Rd. · Esher, Surrey KT 10 8HB
Tel. (01372) 462 854 · Fax (01372) 467 228

Israel
Avi Sasson Representatives
P.O. Box 9270
61091 Tel Aviv
Tel. (03) 5015322 · Fax (03) 5031986
e-mail: asr@isdn.net.il

Italy
SPII S.p.A.
Via Volpi 37 · 21047 Saronno (VA)
Tel. (02) 9622921 · Fax (02) 9609611
e-mail: spii@centoservizi.it

Korea
Alcatel Dunkermotoren Div. of AVTK
4.Floor, SunghyunB/D, 10-5, Karak-Dong,
Songpa-Ku, Seoul
mobile 0082 193096277
Fax (02) 409-6279
e-mail: jungmoon.myoung@alcatel-vacuum.co.kr

Netherlands
Elmeq Nederland BV
Broeikweg 25 · 2871 RM Schoonhoven
Tel. (0182) 385711 · Fax (0182) 386920
e-mail: info@elmeq.nl

Norge
Stork AS
Brynsveien 100 · 1352 Kolsås
Tel. 67176400 · Fax 67176401
e-mail: stork@stork.no

Slovenia/Croatia
Iskra Standard d.o.o.
Kolarjeva 24 · 1000 Ljubljana
Tel. (01) 4326256 · Fax (01) 2316031

Spain
Elmeq SA
Aprestadora, 19, L-12 LOCAL 3
(Gran Via Center)
08902 L'Hospitalet Llobregat, Barcelona
Tel. (93) 422 7033 · Fax (93) 4323660
e-mail: elmeqsa@compuserve.com

Sweden
AB D.J. Stork
Box 1037
17221 Sundbyberg
Tel. (08) 635 60 00 · Fax (08) 635 60 01
www.djstork.se
e-mail: stork@djstork.se

Switzerland
PLZ 1, 2, 3, 45
Dipl. El. Ing. HTL Hans Ruedi Iselin
Haselweg 3 · 2553 Safnern/Biel
Tel. (032) 355 33 79 · Fax (032) 355 27 29
e-mail: istronag@bluewin.ch

PLZ 40-44, 46-49, 50-59, 80-86, 89
Kipfer & Pekeler GmbH
Pfaffnerweg 31 · 4852 Rothrist
Tel. (062) 794 56 00 · Fax (062) 794 56 01
e-mail: j.pekeler@swissonline.ch

PLZ 6, 7, 87-88, 9
Ivo Mittag
Rebbergstr. 49 · 8049 Zürich
Tel. (01) 342 11 29 · Fax (01) 342 14 79
e-mail: imittag@bluewin.ch

United States of America
Alcatel Dunkermotoren
Division of AVP
10 Langley Rd. Suite 300
MA 02459 Newton
Tel. (617) 630 1180 · Fax (617) 630 1182
e-mail: fschuldt@dunkerne.com

Alcatel Dunkermotoren
Division of AVP Mr. Bob Ransom
5850 Potomac Dr.
NC 28027 Concord
Tel. (704) 720 9396 · Fax (704) 704 720 9397
e-mail: rrran@vnet.net

Alcatel Dunkermotoren
Division of AVP Mr Roger Pastolka
32924 Danapoplär
CA 92629 Dana Point
Tel. (949) 661 8747 · Fax (949) 661 8748
e-mail: rogerdp@worldnet.att.net

Alcatel Dunkermotoren
Division of AVP
7105 Virginia Rd, Suite 22
IL 60014 Crystal Lake
Tel. (815) 356 1576 · Fax (815) 356 2760
e-mail: dunker@owc.net



Alcatel SEL AG · Unternehmensbereich Bauelemente Dunkermotoren
Allmendstraße 11 · D-79848 Bonndorf, Schwarzwald
www.dunkermotoren.de · info@dunkermotoren.de
Telefon (077 03) 930-0 · Telefax (077 03) 930-210/212