



Type IP Core and Coil Transformers





GE Type IP Transformers for Performance, Reliability and Service Life

Choosing a brand of dry type core and coil transformer for your electrical equipment is an important decision. You need one that will perform to your customer's expectations. One that will last longer than the equipment itself.

Since 1928, original equipment manufacturers have chosen GE transformers for those very reasons.

All GE Type IP core and coil transformers are made with high quality, grain-oriented electrical steel and magnetic wire using GE proprietary processes. Coils are automatically wound by numerically controlled machines. Products are assembled by a skilled work force that utilizes Six Sigma quality procedures. Each unit is 100% tested per NEMA, UL and ANSI standards using a custom-made automated test equipment system. Units that pass all electrical tests and meet stringent inspection criteria are proudly tagged with the tester's name. It's no wonder that, in survey after survey, people equate the GE name with quality.

World-class quality and systems integration

An increasingly competitive global market demands equipment that meets world-class quality and systems integration requirements. The standard line of Type IP transformers is UL and C-UL listed. Additionally, a series of "CE" compliant transformers is now available that satisfies the low voltage directive EN60742 (European norm).

Because system compatibility is so important in today's complex control schemes, Type IP appearance and performance characteristics form a perfect link in an integrated control system that utilizes GE world-class circuit breakers and controls.



Application Guide

Type IP transformers are core and coil units designed for machine tool, industrial control, panelboard, and general purpose applications.

Several types of terminations are available to simplify installation. These include primary and secondary leads out, integral fuse holder assemblies and the standard terminal block finished into the epoxy encapsulation. Consult your local GE Electrical Distribution & Control sales office for complete technical applications data.

Standards: Type IP units conform to ANSI C89.2. They are UL and C-UL listed under UL-506, file E2739.

Insulation classes: Generally, 150 VA and below are 105°C insulation class, 55°C rise. 200 VA and above are 185°C (NEMA), 180°C (UL) insulation class, 115°C rise. Maximum surface temperature is 65°C.

Frequency: 60 Hertz is standard; 50 Hertz is available as an option.

Voltage regulation: All designs 2.0 kVA and below are compensated for voltage drop. Generally, this compensation ranges from 10% in the smallest rating to 3% for the largest. All machine tool designs meet or exceed NMTBA regulation requirements.

Series-multiple secondary connections: Transformers with 120/240V secondaries (series-multiple) may be connected for 120V, 240V or 240/120V three-wire. Jumpers are provided.

Overcurrent protection: Type IP transformers are low impedance transformers that require overcurrent protection for most applications. They provide for optional integral primary and/or secondary fusing.

Mounting dimensions: Type IP transformers are lightweight, small and designed for minimum mounting dimensions. Many units will fit competitors' mounting footprints.



Step-by-step Selection of Core and Coil Transformers

1. Determine the input voltage, output voltage and frequency.
2. Determine the continuous power (VA) drawn by each load device.

Calculate the maximum continuous power of all load devices that could be energized at the same time.

3. Determine if any of the load devices are voltage sensitive. NEMA standards require electromagnetic components to operate reliably at 85% of rated voltage. This includes devices such as contactors, relays and solenoids.

For applications with voltage sensitive devices, determine the inrush current of each load device. Inrush is the power (VA) drawn by a device the instant it is energized. Electromechanical devices have an inrush from 3 to 10 times their continuous power rating. The inrush of resistive devices is the same as their continuous power rating.

Calculate the maximum inrush power. This is the inrush of all devices being energized at a given instant, plus the continuous power of all devices already energized. A number of load device combinations may have to be examined to determine which produces the maximum inrush current.

4. Use the transformer selection tables to determine the correct catalog number. Select a unit capable of carrying the maximum continuous power. If any load devices are voltage sensitive, select a transformer capable of carrying both the maximum continuous power and the maximum inrush power. Inrush VA listed in selection tables is for .20 PF loads and 95% secondary voltage output. This assures 85% voltage will be supplied to loads on the secondary even if voltage from the primary source is reduced as much as 10%. If you cannot find the exact unit you need, have your GE distributor contact our Customer Service Center.

50-3000VA, Encapsulated Open Core and Coils

GE Type IP transformers are now encapsulated designs to provide the highest quality electrical performance. The transformer coil is completely surrounded by epoxy, making the unit impervious to external elements.

Terminations are made of a new, rugged, high-impact plastic terminal strip. Full head #8 brass screws assure quick, easy terminations with maximum connection integrity.

The encapsulated design retains dimensions and footprint similar to our previous style core and coil units for easy exchange.

Options

Secondary fusing: Factory or field installed secondary fuse clips are available. They are restricted to units with terminal strips and a single secondary voltage or secondary with one tap.

Dual primary and secondary fusing: Factory or field installed dual primary and secondary fusing is available on all units, including leads out and multiple secondary voltages.

Leads out: Terminal strip is replaced by rugged primary and secondary leads emanating from the top of the encapsulated coil.

(Note: Refer to page 9 for CE compliant transformers)

Machine Tool Applications

Single-Phase

Continuous kVA	Frame Size	Inrush VA at .20 PF, 95% sec. volt	Catalog Number Terminal Board
220/440, 230/460, 240/480 Volts Primary — 110, 115, 120 Volts Secondary — 60 Hertz			
.050	611	193	9T58K0042
.075	612	303	9T58K0043
.100	811	396	9T58K0044
.150	813	724	9T58K0045
.200	814	821	9T58K0046
.250	815	1034	9T58K0047
.300	817	1307	9T58K0048
.375	817	1441	9T58K0049
.500	1016	2027	9T58K0050
.750	12225	3092	9T58K0051
1.0	12300	4494	9T58K0052
1.5	14225	5156	9T58K0053
2.0	14300	9193	9T58K0054
3.0	14475	14513	9T58K0056
230/460/575 Volts Primary — 115/95 Volts Secondary — 50/60 Hertz			
.050	613	196	9T58K0062
.075	811	278	9T58K0063
.100	813	445	9T58K0064
.150	815	663	9T58K0065
.200	815	864	9T58K0066
.250	817	1137	9T58K0067
.300	1016	1412	9T58K0068
.375	1016	1670	9T58K0069
.500	1016	1822	9T58K0070
.750	12300	3524	9T58K0071
1.0	14225	4392	9T58K0072
1.5	14300	6753	9T58K0073
2.0	14475	11563	9T58K0074
208/277/380 Volts Primary — 115/95 Volts Secondary — 50/60 Hertz			
.050	613	217	9T58K0082
.075	811	322	9T58K0083
.100	813	464	9T58K0084
.150	815	761	9T58K0085
.200	815	837	9T58K0086
.250	817	1198	9T58K0087
.300	1016	1409	9T58K0088
.375	1016	1674	9T58K0089
.500	1016	1821	9T58K0090
.750	12300	3771	9T58K0091
1.0	14225	4234	9T58K0092
1.5	14300	7091	9T58K0093
2.0	14475	11729	9T58K0094



50-3000VA Encapsulated Open Core and Coils

Control Power Applications

Single-Phase

Continuous kVA	Frame Size	Catalog Number	
		Terminal Board	With Primary and Secondary Leads Out ¹
240/480 Volts Primary — 120/240 Volts Secondary — 60 Hertz			
.050	611	9T58K2802	9T58K1802
.075	612	9T58K2803	9T58K1803
.100	811	9T58K2804	9T58K1804
.150	813	9T58K2805	9T58K1805
.200	814	9T58K2806	9T58K1806
.250	815	9T58K2807	9T58K1807
.300	815	9T58K2808	9T58K1808
.375	817	9T58K2809	9T58K1809
.500	1016	9T58K2810	9T58K1810
.750	12225	9T58K2811	9T58K1811
1.0	12300	9T58K2812	9T58K1812
1.5	14225	9T58K2813	9T58K1813
2.0	14300	9T58K2814	9T58K1814
3.0	14475	9T58K2815	9T58K1815
600 Volts Primary — 120/240 Volts Secondary — 60 Hertz			
.100	811	9T58K2824	9T58K1824
.200	814	9T58K2826	9T58K1826
.300	815	9T58K2828	9T58K1828
.500	1016	9T58K2830	9T58K1830
1.0	12300	9T58K2832	9T58K1832
2.0	14300	9T58K2834	9T58K1834
3.0	14475	9T58K2835	9T58K1835
120/240 Volts Primary — 120/240 Volts Secondary — 60 Hertz			
.100	811	9T58K2907	—
.200	814	9T58K2909	—
.300	815	9T58K2911	—
.500	1016	9T58K2913	—
.750	12225	9T58K2914	—
1.0	12300	9T58K2915	—
2.0	14300	9T58K2917	—
3.0	14475	9T58K2918	—

¹Secondary fusing not available.

Continuous kVA	Frame Size	Catalog Number	
		Terminal Board	With Primary and Secondary Leads Out ¹
120/240 Volts Primary — 12/24 Volts Secondary — 60 Hertz			
.050	611	9T58K2873	9T58K1873
.075	612	9T58K2874	9T58K1874
.100	811	9T58K2875	9T58K1875
.150	813	9T58K2876	9T58K1876
.200	814	9T58K2877	9T58K1877
.250	815	9T58K2878	9T58K1878
.300	815	9T58K2879	9T58K1879
.500	1016	—	9T58K1881
240/480 Volts Primary — 120/240 Volts Secondary — 50/60 Hertz			
.500	1016	9T58K2930	9T58K1930
.750	12300	9T58K2931	9T58K1931
1.0	14225	9T58K2932	9T58K1932
1.5	14300	9T58K2933	9T58K1933
2.0	14475	9T58K2934	9T58K1934
3.0	14475	9T58K2935	9T58K1935
380/400/416 Volts Primary — 115/230 Volts Secondary — 50/60 Hertz			
.500	1016	9T58K2978	—
.750	12300	9T58K2979	9T58K1979
1.0	14225	9T58K2980	9T58K1980
1.5	14300	9T58K2981	9T58K1981
2.0	14475	9T58K2982	9T58K1982
3.0	14475	9T58K2983	—
240/480 Volts Primary — 12/24 Volts Secondary — 60 Hertz			
.050	611	9T58K3164	—
.100	811	9T58K4132	—
.150	813	9T58K4133	—
.250	815	9T58K3024	—
208/240 Volts Primary — 12/24 Volts Secondary — 60 Hertz			
.050	611	9T58K4050	—
.100	811	9T58K4051	—
.150	813	9T58K4052	—
.250	815	9T58K4053	—

¹Secondary fusing not available.

Options and Fusing Guide

Encapsulated Transformer Options

Fuse Clips Mounted On Terminals	Fuse Blocks Mounted On Top Of Transformer							Terminal Links (Standard Terminal Blocks)	Terminal Block Covers (Standard Terminal Blocks) ²
	Single 1/4" x 1 1/4" Glass Fuse ¹	Single 1/4" x 1 1/4" Glass Fuse	Single 13/32" x 1 1/2" Midget Fuse	Single 9/16" x 2" H/K Fuses	Dual 9/16" x 2" H/K Fuses	Dual 13/32" x 1 1/2" Class CC Fuses with Single 1/4" x 1 1/4" Glass Fuse	Dual 13/32" x 1 1/2" Class CC Fuses with Single 13/32" x 1 1/2" Midget Fuse		
9T58K0000									9T58E0000
-G09	-G24	-G42	-G10	-G05	-G48	-G38	-G18	-G01	-G35

¹ Use G24 when the transformer is a series multiple or multi-tapped winding with no open terminals.

² Terminal block cover is standard on "CE" marked designs. Prefix for this catalog number is 9T58E.

Fuse Guide¹

Midget Class CC Rejection Fuse

Primary Voltage	Encapsulated Transformer Continuous Power Rating (VA)								
	50	75	100	150	200	250	300	375	500
	Fuse Rating (amperes)								
100	1.50	2.00	3.00	4.00	3.00	4.00	5.00	6.00	8.00
110	1.25	2.00	2.50	4.00	5.00	3.00	4.00	5.00	7.00
120	1.25	1.60	2.50	3.00	5.00	3.00	4.00	5.00	6.00
200	0.75	1.00	1.50	2.00	3.00	3.00	4.00	5.00	4.00
208	0.60	1.00	1.25	2.00	2.50	3.00	4.00	5.00	4.00
220	0.60	1.00	1.25	2.00	2.50	3.00	4.00	5.00	3.00
230	0.60	0.80	1.25	1.60	2.50	3.00	3.00	4.00	3.00
240	0.60	0.80	1.25	1.60	2.50	3.00	3.00	4.00	3.00
277	0.50	0.80	1.00	1.60	2.00	2.50	3.00	4.00	5.00
380	0.30	0.50	0.75	1.00	1.50	1.60	2.00	2.50	3.00
400	0.30	0.50	0.75	1.00	1.50	1.60	2.00	2.50	3.00
416	0.30	0.50	0.60	1.00	1.25	1.60	2.00	2.50	3.00
440	0.30	0.50	0.60	1.00	1.25	1.60	2.00	2.50	3.00
460	0.30	0.40	0.60	0.80	1.25	1.60	1.60	2.00	3.00
480	0.30	0.40	0.60	0.80	1.25	1.50	1.60	2.00	3.00
550	0.25	0.40	0.50	0.80	1.00	1.25	1.60	2.00	2.50
575	0.25	0.30	0.50	0.75	1.00	1.25	1.50	1.60	2.50
600	0.25	0.30	0.50	0.75	1.00	1.25	1.50	1.60	2.50

¹ For motor control circuits fusing, refer to NEC 430-72.

Secondary Fuse Selection

Glass Fuse

Secondary Voltage	Encapsulated Transformer Continuous Power Rating (VA)								
	50	75	100	150	200	250	300	375	500
	Fuse Rating (amperes)								
12	6.00	10.00	12.00	15.00	20.00	25.00	30.00	—	—
24	3.00	5.00	6.00	10.00	12.00	12.00	15.00	—	25.00
36	2.00	3.00	4.00	6.00	8.00	10.00	12.00	12.00	15.00
48	1.60	2.50	3.00	5.00	6.00	8.00	10.00	12.00	12.00
95	0.80	1.25	1.60	2.50	3.00	4.00	5.00	6.00	8.00
110	0.75	1.00	1.50	2.00	3.00	3.00	4.00	5.00	7.00
115	0.60	1.00	1.25	2.00	2.50	3.00	4.00	5.00	7.00
120	0.60	1.00	1.25	2.00	2.50	3.00	4.00	5.00	6.00
208	0.40	0.60	0.80	1.00	1.60	2.00	2.00	3.00	4.00
220	0.30	0.50	0.75	1.00	1.50	1.60	2.00	2.50	3.00
230	0.30	0.50	0.60	1.00	1.25	1.60	2.00	2.50	3.00
240	0.30	0.50	0.60	1.00	1.25	1.60	2.00	2.50	3.00

Secondary Voltage	Encapsulated Transformer Continuous Power Rating (VA)				
	750	1000	1500	2000	3000
	Fuse Rating (amperes)				
95	12	15	20	25	—
110	10	12	20	25	30
115	10	12	20	20	30
120	10	12	15	20	30
208	6	8	12	15	20
220	5	7	10	12	20
230	5	7	10	12	20
240	5	6	10	12	15
	Glass fuse			H-K fuse	



6, 8 and 10 Frame

Terminal block

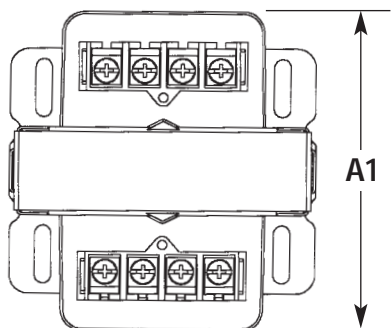

TOP

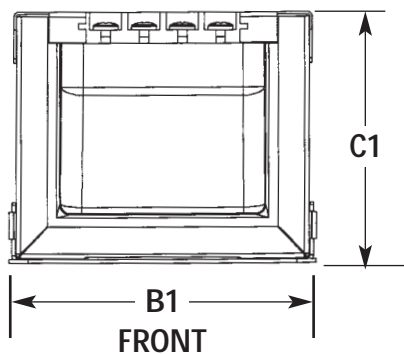

FRONT

Encapsulated Transformer Dimensions and Weights

Frame	Ref 60Hz kVA	Approx Weight (lbs)	Dimensions (inches)								
			Maximum Envelope						Mounting		
			Depth		Width		Height		Depth	Width	Slot
A1	A2	B1	B2	C1	C2	E	F	G			
611	.050	2.6	3.97	3.18	3.29	3.29	2.79	2.64	2.16	2.50	.219 x .750
612	.075	3.0	4.22	3.43	3.29	3.29	2.79	2.64	2.41	2.50	.219 x .750
613	.087	3.4	4.47	3.68	3.29	3.29	2.79	2.64	2.66	2.50	.219 x .750
811	.100	3.9	4.17	3.18	4.04	4.04	3.29	3.29	2.16	3.12	.219 x .750
813	.150	5.5	4.67	3.68	4.04	4.04	3.29	3.29	2.66	3.12	.219 x .750
814	.200	6.3	4.92	3.93	4.04	4.04	3.29	3.29	2.91	3.12	.219 x .750
815	.250	7.0	5.17	4.18	4.04	4.04	3.29	3.29	3.16	3.12	.219 x .750
817	.375	8.3	5.67	4.68	4.04	4.04	3.29	3.29	3.66	3.12	.219 x .750
1016	.500	11.6	5.82	5.82	4.79	4.79	3.92	3.92	3.31	3.79	.297 x .590 ¹

¹The mounting slots on the 1016 frame run side-to-side (parallel to the "F" dimension) rather than front-to-rear (parallel to the "E" dimension) as shown.

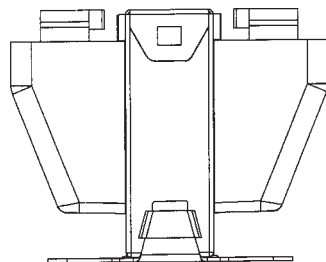

SIDE

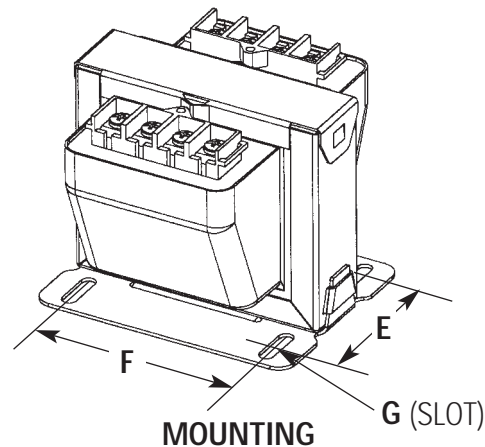

MOUNTING

Leads out

A2 dimension is less than A1 on units built on 6 and 8 frame core sizes.

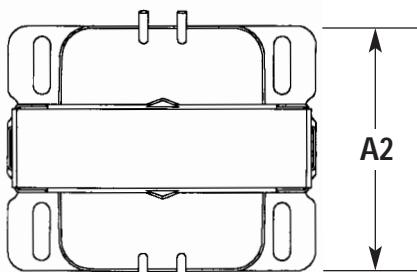

TOP

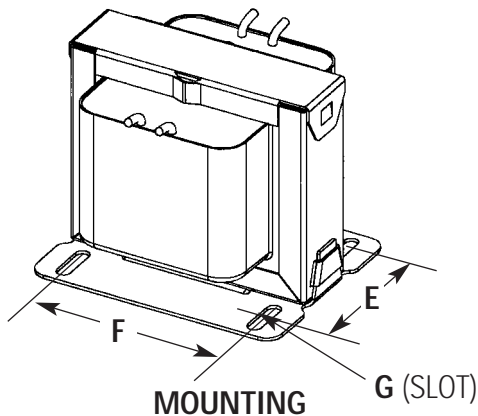

MOUNTING

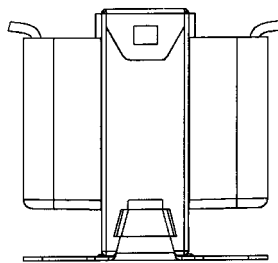

SIDE

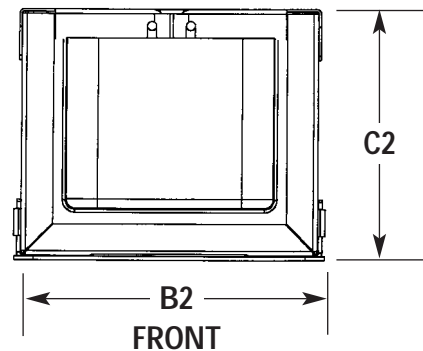

FRONT

12 and 14 Frame

Terminal block

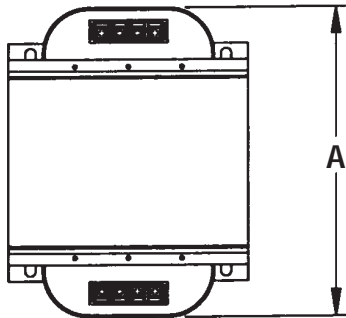

TOP

Encapsulated Transformer Dimensions and Weights

Frame	Ref 60 hz KVA	Approx Weight (lbs)	Dimensions (inches)					
			Maximum Envelope			Mounting		
			Depth	Width	Height	Depth	Width	Slot
			A	B	C	E	F	G
12225	.75	13.0	5.81	5.31	4.62	3.38	4.0	.297x.580
12300	1.00	17.5	6.56	5.31	4.62	4.12	4.0	.297x.580
14225	1.50	29.0	6.31	6.81	5.88	3.38	5.5	.297x.580
14300	2.00	35.5	7.06	6.81	5.88	4.12	5.5	.297x.580
14475	3.00	51.5	8.81	6.81	5.88	5.88	5.5	.297x.580

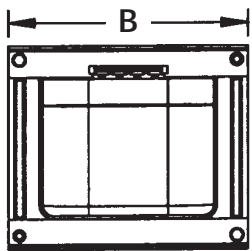

FRONT

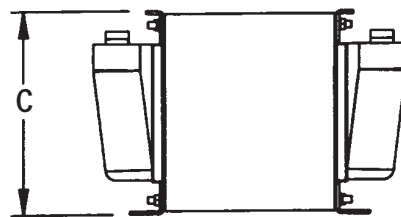

SIDE

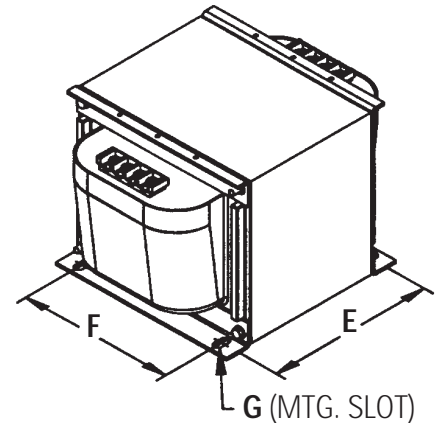

MOUNTING

Leads out

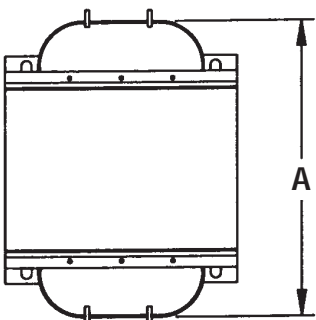

TOP

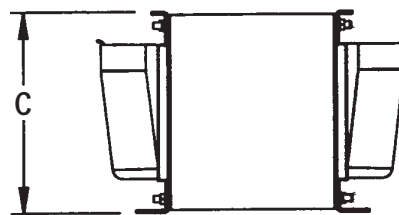

SIDE

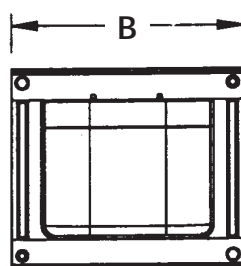

FRONT

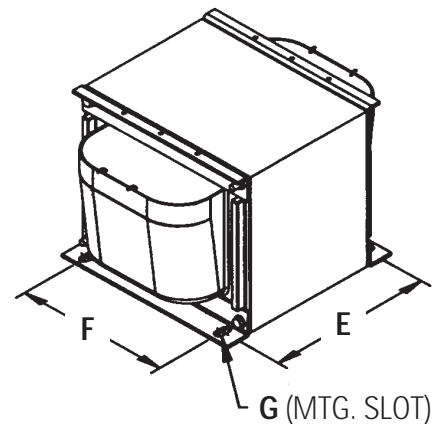

MOUNTING



CE Compliant Transformers

The CE compliant transformer offering developed by GE is of the highest quality. This product is designed to be incorporated into equipment manufactured for sale in the European Community. This product is in conformity with the European Standard: EN 60 742, 1995 per the provisions of the Low Voltage (LV) Directive 73/23/EEC in 1973 as amended by 93/68/EEC in 1995.

The Type IP CE offering utilizes all copper windings, which are encapsulated in a hardened epoxy, making the winding impervious to the elements. These designs are rated at 55° C rise with a 40° C ambient. Standard on these designs are terminal board covers. These provide protection from current carrying terminals for personnel working on the equipment. These designs incorporate customer friendly connection on rugged high-impact molded terminal boards.

Besides being CE rated, these designs are both UL and C-UL Listed.

Available as an option are two fuse blocks that have fuse covers that provide the touch safety like the terminal covers. These can be ordered factory installed or as kits.

In kit form order:
 Fuse block for 2 class CC fuses is 9T58E0000G46,
 Fuse block for 2 class CC and 1 Midget fuse is 9T58E0000G47.

For factory installation add the G46 or G47 suffix to the transformer catalog number (example 9T58E0020G47).

Single-Phase

Catalog Number	VA	Frame Size
Safety Isolation, 230/400 volts primary 12/24 volts secondary, 50/60 Hz		
9T58E0020	25	611
9T58E0021	50	613
9T58E0023	75	811
9T58E0024	100	813
9T58E0025	150	815
9T58E0026	200	1016
9T58E0027	250	1016
9T58E0028	300	1016
9T58E0029	375	12200
Isolation, 230/400 Volts Primary 24/48 volts secondary, 50/60 Hz		
9T58E0060	25	611
9T48E0061	50	613
9T58E0063	75	811
9T58E0064	100	813
9T58E0065	150	815
9T58E0066	200	1016
9T58E0067	250	1016
9T58E0068	300	1016
9T58E0069	375	12200
9T58E0071	500	12275
9T58E0073	750	14200
Isolation (TRIPLE RATED) 220/380, 230/400, 240/415 Volts Primary 110/220, 115/230, 120/400 Volts Secondary, 50/60 Hz		
9T58E0150	25	611
9T58E0151	50	613
9T58E0153	75	811
9T58E0154	100	813
9T58E0155	150	815
9T58E0156	200	1016
9T58E0157	250	1016
9T58E0158	300	1016
9T58E0159	375	12200
9T58E0161	500	12275
9T58E0163	750	14200
9T58E0164	1000	14300
9T58E0165	1500	14400

CE Compliant Transformers

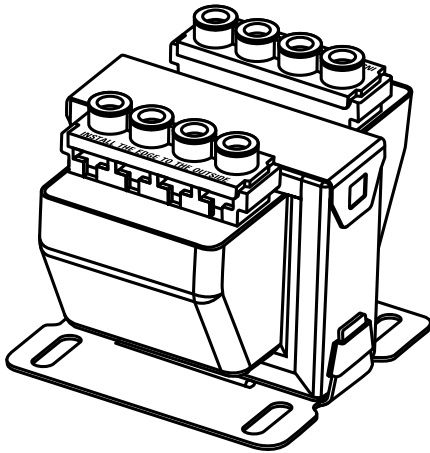

Style AA

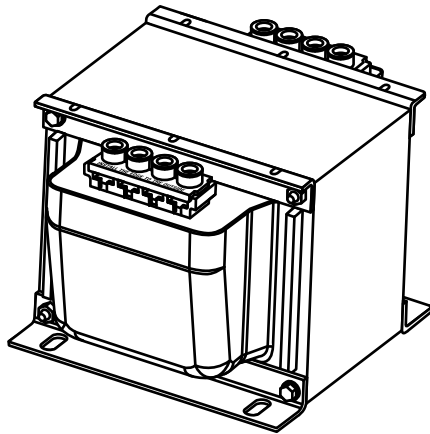

Style BA

Fuse Block Option
 Note: Fuse Block option may include 2 or 3 pole fuse block

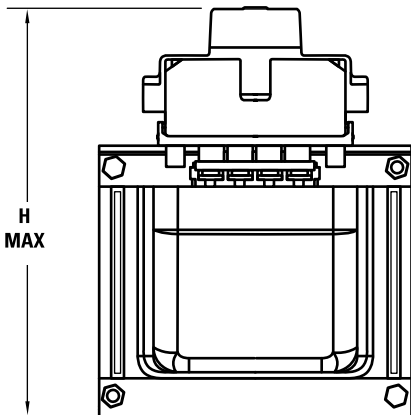

Style	Frame	Approx Weight (lbs)	Dimensions (inches)					
			Maximum Envelope			Mounting		
			Depth	Width	Height	Depth	Width	Slot
			A	B	C	E	F	G
AA	611	2.6	3.97	3.29	3.08	2.16	2.50	.219 x .750
	612	3.0	4.22	3.29	3.08	2.41	2.50	.219 x .750
	613	3.4	4.47	3.29	3.08	2.66	2.50	.219 x .750
	811	3.9	4.17	4.04	3.60	2.16	3.12	.219 x .750
	813	5.5	4.67	4.04	3.60	2.66	3.12	.219 x .750
	814	6.3	4.92	4.04	3.60	2.91	3.12	.219 x .750
	815	7.0	5.17	4.04	3.60	3.16	3.12	.219 x .750
	817	8.3	5.67	4.04	3.60	3.66	3.12	.219 x .750
	1016	11.6	5.82	4.79	4.17	3.31	3.79	.297 x .590
BA	12200	11.5	5.56	5.31	4.62	3.12	4.00	.297 x .580
	12225	13.0	5.81	5.31	4.62	3.38	4.00	.297 x .580
	12275	16.0	6.31	5.31	4.62	3.88	4.00	.297 x .580
	12300	17.5	6.56	5.31	4.62	4.12	4.00	.297 x .580
	14200	26.8	6.06	6.81	5.88	3.12	5.50	.297 x .580
	14225	29.0	6.31	6.81	5.88	3.38	5.50	.297 x .580
	14250	31.2	6.56	6.81	5.88	3.62	5.50	.297 x .580
	14300	35.5	7.06	6.81	5.88	4.12	5.50	.297 x .580
	14350	40.2	7.56	6.81	5.88	4.62	5.50	.297 x .580
	14400	44.8	8.06	6.81	5.88	5.12	5.50	.297 x .580
	14475	51.5	8.81	6.81	5.88	5.88	5.50	.297 x .580

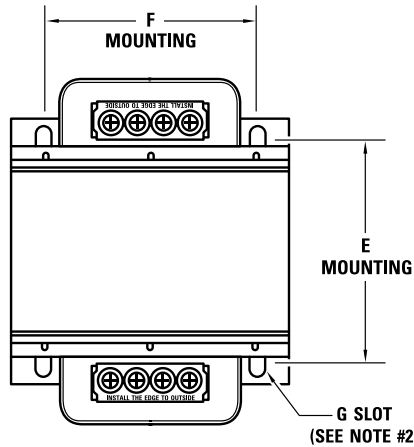

Frame Series	Fuse Block Option	
	Dimensions (inches)	
	H 2 Pole Fuse Block	H 3 Pole Fuse Block
600	5.05	N/A
800	5.67	5.67
1000	6.30	6.30
12000	6.97	6.97
14000	8.26	8.26

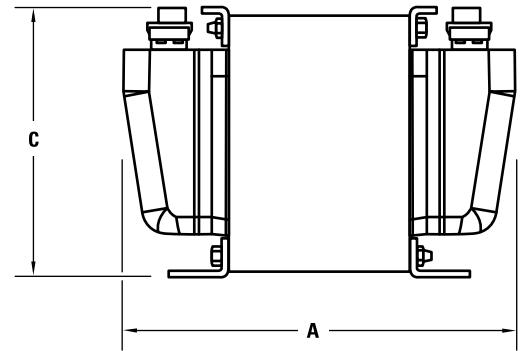
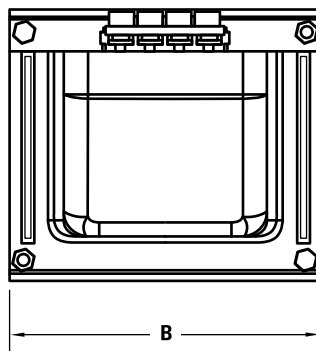



GE Industrial Systems

General Electric Company
41 Woodford Avenue, Plainville, CT 06062
www.ge.com/edc